

The Great Grid Upgrade

Sea Link

Sea Link

Volume 9: Examination Submissions

Document 9.17.2: Kent Drainage Strategy

Planning Inspectorate Reference: EN020026

Version: **0.1BA**
~~October~~ March 20265

nationalgrid

Page intentionally blank

Contents

1.	Introduction	5
1.1	DCO Submission	5
1.2	Project Overview and Scope	5
1.3	Drainage Stakeholders Consultation	7
2.	Kent Sea Link Route	8
2.1	Site Description	8
2.2	Cable Route	8
2.3	Data Sources	8
2.4	Standards and Guidance	10
3.	Existing Topography	12
3.2	Existing Topographical Survey taken during 2023	13
4.	Existing Hydrology	14
4.2	Watercourses	14
4.3	Lakes and Reservoirs	17
4.4	Existing Sewers	17
4.5	Existing Field Drainage	17
4.6	Flood Zones	18
5.	Existing Ground Conditions	20
5.2	Geology	20
5.3	Contaminated Land	21
5.4	Groundwater and Source Protection Zones (SPZ)	21
6.	Surface Water Drainage Design Strategy	22
6.1	Overview	22
6.2	Design Guidance and Policy	22
6.3	Runoff Destination	24
6.4	Management of Extreme Rainfall and Flooding	25
6.5	Management of Everyday Rainfall (Interception)	33
6.6	Proposed Drainage Features	34
6.7	Field Drainage Management	37
6.8	Groundwater Management Features	39

7.	Foul Water Drainage	42
7.2	Temporary Foul Water	42
7.3	Permanent Foul Water	42
8.	Water Quality	43
8.2	Consents	47
9.	Amenity	50
10.	Biodiversity	51
11.	Design of Drainage for Construction, Operation, Maintenance, decommissioning and Structural Integrity	52
11.2	Maintenance	52
11.3	Decommissioning	53
11.4	Structural Integrity	54
12.	Conclusions and Recommendations	55
12.1	Assumptions and Risks	55
12.2	Opportunities	56
Appendix A	Preliminary Drainage Design Summary	A.1
Appendix B	Drainage Layouts	B.1
Appendix C	Additional Insets	C.1
Appendix D	Consultation Responses	D.1
Appendix E	Drainage Strategy Summary Form	E.1
	Plate 1.1 Sea Link proposed marine routing	6
	Plate 3.1 Existing Elevations	13
	Plate 4.1 Sub-areas and Flood Risk Management Policies for River Stour	14
	Plate 4.2 River Stour Drainage District	16
	Plate 4.3 Typical land drainage layouts	18
	Plate 6.1 Climate change uplift allowances	24
	Plate 6.2 PIMP values for a typical cable construction layout	29
	Plate 6.3 Overall % PIMP calculations for HVDC construction swathe	31
	Plate 6.4 Basin with Forebay detail	35
	Plate 6.5 Proposed swale to intercept flows from the permeable subbase of the platforms	36
	Plate 6.6 Headwall detail with scour protection for permanent works	37
	Plate 6.7 Indicative trench cross section	38
	Plate 6.8 Field drainage diversion layout example	39
	Plate 6.9 Spaced puddle clay stanks along the cable route in the areas prone to groundwater risk	41

Plate 8.1 Outfalls with bank protection for discharge outfall and baffles on discharge hoses for temporary works	45
Table 2.1 Data sources used for assessment	9
Table 2.2 Standards and guidance used for assessment	10
Table 4.1 Cable route watercourse crossings	16
Table 6.1 Independent networks forming drainage strategy	27
Table 6.2 Overall % PIMP (Percentage of Impervious Area) values for a typical cable construction layout	28
Table 6.3 Overall % PIMP values for HVDC construction swathe	30
Table 6.4 Overall % PIMP calculations for the combined permanent substation and converter station	33
Table 11.1 SuDS maintenance plan description	53

Sea Link Document Control

Version History

Date	Version	Status	Description / Changes
<u>November 2025</u>	A	FINAL	First issue <u>for Deadline 3 submission</u>
<u>March 2026</u>	<u>B</u>	<u>FINAL</u>	<u>Update following stakeholder feedback</u>

1. Introduction

1.1 DCO Submission

- 1.1.1 This Drainage Strategy and the preliminary drainage design drawings have been produced to support the application for Development Consent of the Sea Link Scheme (the Scheme). This strategy provides the outline proposals for drainage required for the construction and operation of the relevant onshore elements of the proposed development in Kent.
- 1.1.2 This strategy is intended to provide additional information to that provided in Appendix C of **Application Document 6.8 Flood Risk Assessment [APP-292]**. The strategy is unchanged from that document; however, this document provides site specific detail and demonstrates compliance with the following:
- National standards for sustainable drainage systems (SuDS) first published in June 2025.
 - National Policy Statement for Energy EN-1 published November 2023.

1.2 Project Overview and Scope

- 1.2.1 National Grid Electricity Transmission has developed proposals for Sea Link, a new planned high voltage undersea electrical link between Suffolk and Kent. Sea Link will add much needed capability to the electricity transmission network, enabling low carbon and green energy from other projects to connect to the network and be transported around the country.

Plate 1.1 Sea Link proposed marine routing

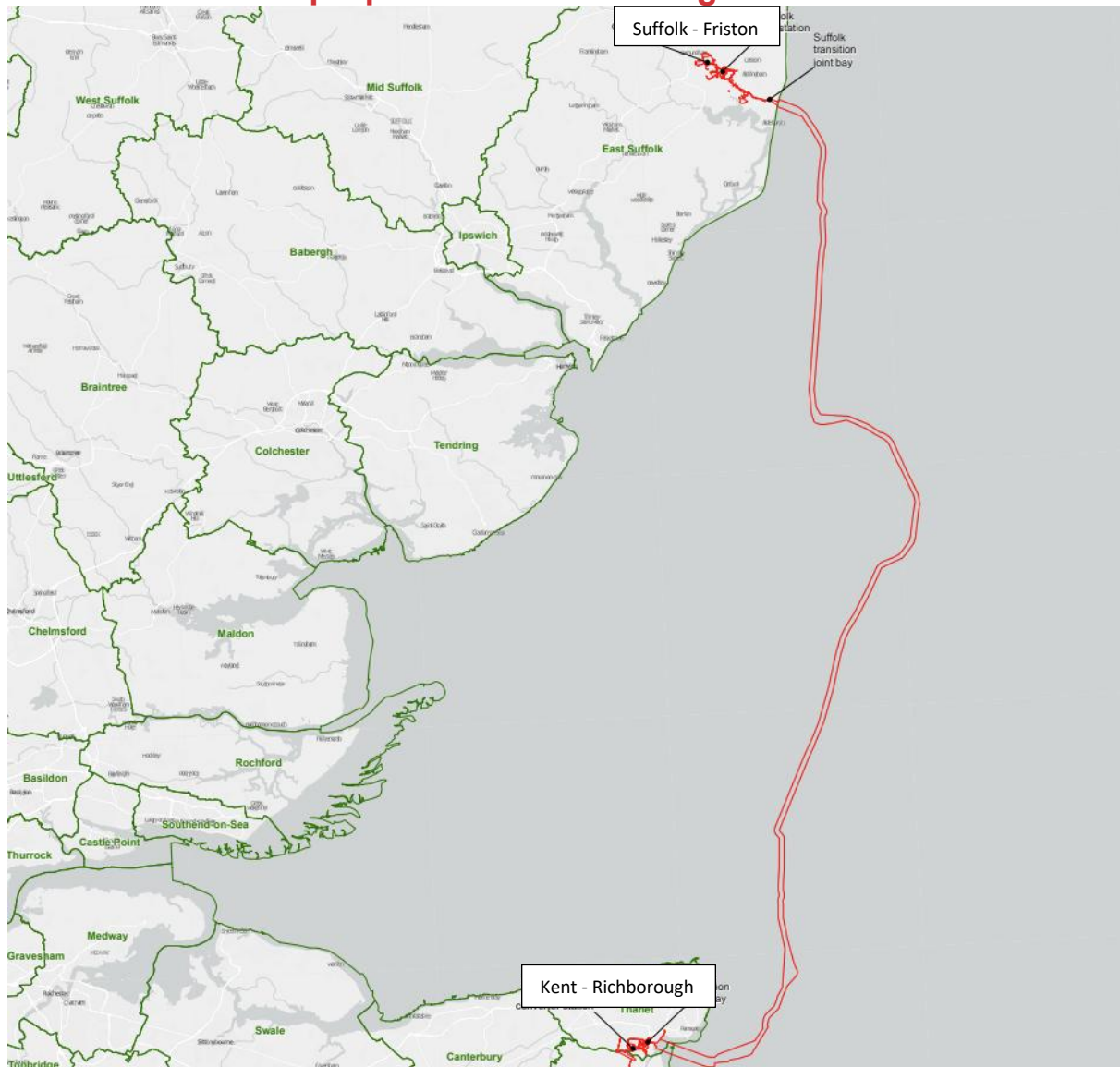

Plate 1.1 Sea Link proposed marine routing

Source: 2.2 Location Plans [APP-018]

- 1.2.2 The Sea Link project involves a 2GW HVDC link between Richborough in Kent and Frinton in Suffolk which forms part of the solution to resolve the operational boundary issues in the South Coast, East Coast and London Areas.
- 1.2.3 The Scheme includes the installation of onshore HVDC cable alignments in Kent and Suffolk, and the siting of HVDC/HVAC converter station and HVAC connections to the associated substations. The onshore Suffolk section and a HVDC underground route from the Suffolk converter station to the landfall point in Kent of circa 120km offshore subsea cables are not covered by this drainage strategy.
- 1.2.4 To enable the Sea Link project to be connected to the wider electricity transmission network, the Kent Sea Link project (the focus of this report), comprises an onshore HVDC cable route, a new converter station and substation within 1.5km of the existing Richborough 400kV substation, and a new High Voltage Alternative Current (HVAC) overhead line to the existing Richborough 400kV.

- 1.2.5 The HVDC cable route will be buried for the entire length using a combination of open cut trench and potentially trenchless solutions (e.g., Horizontal Directional Drilling (HDD)) in some locations. The majority of the construction swathe comprises undeveloped agricultural land. Details of HVDC construction swathe are proposed in **2.13 Design and Layout Plans [APP-037]**.
- 1.2.6 For further details describing the Scheme as a whole, refer to **6.2.1.4 Part 1 Introduction Chapter 4 Description of the Proposed Project [APP-045]**.
- 1.2.7 This report has been informed by feedback received during Statutory Consultation alongside ongoing consultation meetings with the relevant stakeholder bodies during 2023 and 2024.
- 1.2.8 During 2024 a site investigation by Structural Soils Ltd was taken, where soakaways and intrusive boreholes were carried out along the cable route. Additionally, in October 2023 a topographical survey was conducted by 3D Engineering Surveys Limited.

1.3 Drainage Stakeholders Consultation

- 1.3.1 Stakeholders have been consulted during the preparation of this drainage strategy, to ensure clear information is communicated regarding general industry practice and the development of solutions at key constraints. These include the following:
- The Environment Agency (EA) is the principal flood risk management authority in England providing a strategic overview relating to all forms of flood and coastal erosion risk. They are responsible for water quality and resources, and management of risk of flooding from main rivers, reservoirs, estuaries and the sea.
 - Kent County Council (KCC) is the Lead Local Flood Authority and is responsible for managing the risk of flooding from surface water, groundwater and ordinary watercourses, and leading on community recovery
 - River Stour (Kent) Internal Drainage Board (IDB) is the land drainage authority within the River Stour drainage district and is responsible for managing water levels both in watercourses and underground (groundwater), by improving and maintaining ordinary watercourses, drainage channels and pumping stations to reduce the risk of flooding. Their functions include supervising land drainage and flood defence works on ordinary watercourses within their drainage district boundary.
- 1.3.2 Consultation continues throughout the lifecycle of a project, from its initial stages through to consent and post-consent.
- 1.3.3 Section 4.2 of this report states the ownership of the existing watercourses that interface with the cable route options; and Section 8.2 describes all consents required to discharge water into an existing watercourse or working near a watercourse.
- 1.3.4 A summary of the consultation (feedback and responses received from stakeholders) is provided in Appendix D.

2. Kent Sea Link Route

2.1 Site Description

- 2.1.1 The majority of the construction swathe comprises undeveloped agricultural land. Additionally, nearby residential developments, road developments, the historical railway line, Minster Stream and the River Stour, sewage treatment works, and Richborough Energy Park have been identified in proximity to the construction swathe.

2.2 Cable Route

- 2.2.1 The general arrangement for the FEED Design for Kent Sea Link is within the DCO application **2.14.2 Indicative General Arrangements Plans – Kent [APP-039]**. The proposed cable route is located between E634628, N163608 and E630503, N163058. The route runs east to west from Sandwich and Pegwell Bay linking to the south with the existing Richborough Substation; and the haul road links to the existing Gore Street Road.
- 2.2.2 The cable alignment enters land through Horizontal Directional Drilling (HDD) south of Cliffsend. The HDD crossing avoids two identified landfill sites. This HDD crossing will be passing underneath Stone St Augustine's Golf Course and Sandwich Road. On the marine side the HDD will be entering at Pegwell Bay which is considered a Site of Special Scientific Interest (SSSI); an important wetland bird area which is unavoidable due to its extent.
- 2.2.3 The proposed converter station and substation will be located within an area of agricultural fields approximately 275m north of the existing Weatherlees Hill Wastewater Treatment Works.
- 2.2.4 The HVDC cable route corridor comprises a standard 40m wide construction swathe with localised widening at locations of proposed construction compounds. The length of the HVDC cable route is 1.47km approximately. The initial length of the HVDC cable route passes across St Augustine's Golf Club before crossing agricultural land and the A256 Richborough Way. The remainder of the HVDC cable route between the A256 and the substation / converter station site crosses agricultural land.
- 2.2.5 The proposed connection between the substation / converter station and the existing overhead line (OHL) is a new OHL route connecting into the existing OHLs.

2.3 Data Sources

- 2.3.1 The following data sources have been used for this assessment:

Table 2.14 Data sources used for assessment

NAME	FILE REF	SOURCE	DATE	REVISION
Ordnance Survey Mapping	SEAL OS Mapping_OS GB36	Ordnance Survey	2022	N/A
Aerial maps, Openstreet maps	N/A	Google Maps and Earth, Bing	2022	N/A
Magic Map Website: Source Protection Zones	N/A	Environment Agency	2022	N/A
British Geological Survey (BGS) Website: Historic borehole records and geological maps	N/A	BGS website	2022	N/A
Geotechnical and Geo-environmental Preliminary Risk Assessment (Desk Study) Report - Richborough	SEAL-MMD-SEAL-ENG-REG-0057	Mott MacDonald	2022	01
OSTerrain 5	N/A	Ordnance Survey	2022	N/A
River Stour IDB Drainage District	Map1 ¹	Kent County Council	N/A	N/A
Geology (solid) of the Drainage District	Map 2 ²	Kent County Council	N/A	N/A
RSIDB Maintained watercourses	Map 3 ³	Kent County Council	N/A	N/A
International sites - SSSIs in the Lower Stour	Map10 ⁴	Kent County Council	N/A	N/A
Interface with River Stour (Kent) Internal	SEAL-MMD-SEAL-ENG-REP-0480	Mott MacDonald	2022	01

¹ <https://rsidb.org.uk/wp-content/uploads/2021/06/MAP-1-DISTRICT-BOUNDARY.pdf>

² <https://rsidb.org.uk/wp-content/uploads/2021/06/MAP-2-GEOLOGY-OF-THE-DISTRICT.pdf>

³ <https://rsidb.org.uk/wp-content/uploads/2021/06/MAP-3-RSIDB-MAINTAINED-WATERCOURSES.pdf>

⁴ <https://rsidb.org.uk/wp-content/uploads/2021/06/MAP-10-INTERNATIONAL-SITES-SSSIS-IN-THE-LOWER-STOUR.pdf>

NAME	FILE REF	SOURCE	DATE	REVISION
Drainage Board (IDB)				
Mott MacDonald River Crossing Consultation	KT/2022/130 046/01-L01	Environment Agency	2022	N/A
SEA Link FEED – Kent Onshore Cable Link Factual Report on Preliminary Ground Investigation	563607-01 (03)	Structural Soils Ltd	2024	03

2.4 Standards and Guidance

2.4.1 The following standards and guidance have been followed in this strategy:

Table 2.2 Standards and guidance used for assessment

DOCUMENT NAME	DOCUMENT REFERENCE	PUBLISHER
National Grid - Roadworks and Surfacing	TS 2.10.08	National Grid
National Grid - Site Drainage	TS 2.10.09	National Grid
National Grid - Flood Defences for electricity substations	TS 2.10.13	National Grid
The SuDS Manual	C753	Construction Industry Research and Information Association
Culvert design and operations guide	C786	Construction Industry Research and Information Association
Groundwater control - Design and Practise	C515	Construction Industry Research and Information Association
Control of water pollution from linear construction sites	C648	Construction Industry Research and Information Association

DOCUMENT NAME	DOCUMENT REFERENCE	PUBLISHER
Control of water pollution from construction sites	C532	Construction Industry Research and Information Association
National Planning Policy Framework (NPPF) 2021	NPPF	UK Government
Strategic Flood Risk Assessment ⁵	March 2022	Thanet District Council
Local Flood Risk Management Strategy Document ⁶	2022	Kent County Council
Kent County Council Drainage and Planning Policy Statement	2019	Kent County Council
Department of Environment, Food and Rural Affairs (DEFRA)'s non-statutory technical standards ⁷	N/A	UK Government
Land Drainage Policy (2019)	N/A	Kent County Council
River Stour Catchment Flood Management Plan Summary Report December 2009 ⁸	N/A	Environment Agency
The River Stour (Kent) Internal Drainage Board - Land Drainage Byelaws ⁹	N/A	The River Stour (Kent) Internal Drainage Board
Rural Sustainable Drainage Systems ¹⁰	June 2012 - RSuDS	Environment Agency
Agriculture and Horticulture Development Board ¹¹	AHDB	Agriculture and Horticulture Development Board

5 https://www.thanet.gov.uk/wp-content/uploads/2022/06/3184_Thanet-District-Council_SFRA_March-22_Rev4-reduced-3.pdf

6 <https://www.kent.gov.uk/about-the-council/strategies-and-policies/service-specific-policies/economic-regeneration-and-planning-policies/planning-policies/flooding-drainage-and-water-management-policies-and-guidance/kent-flood-risk-management-plan>

7 <https://www.gov.uk/government/publications/sustainable-drainage-systems-non-statutory-technical-standards>

8 https://assets.publishing.service.gov.uk/media/5a7cbe2aed915d6822362463/Stour_Catchment_Flood_Management_Plan.pdf

9 <https://rsidb.org.uk/>

10 <https://www.gov.uk/government/publications/rural-sustainable-drainage-systems>

11 <https://ahdb.org.uk/>

3. Existing Topography

- 3.1.1 The topography of the site can have a significant impact on the constructability of the cable route, converter station and substation. OSTerrain 5 data obtained from Ordnance Survey has been used to identify the existing topography of the Kent scheme. This dataset has an accuracy 2m Root Mean Squared Error (RMSE).
- 3.1.2 A detailed assessment of the topography affected by the cable route and the surrounding areas was carried out by 3D Engineering Surveys in November 2023 and the drainage strategy uses data from this for the identification of drainage outlets into watercourses.
- 3.1.3 Indicative design elevations for the cable route and individual areas including construction compounds, converter station / substation and crossings are to be confirmed and supplied at a later stage of the project, following more detailed assessment of the topography of the route and the coordination of **Application Document 6.8 Flood Risk Assessment [APP-292]** recommendations, but an initial minimum FFL (Final Floor Level) of the platform is indicated in **Appendix A**.
- 3.1.4 The finish platform level of the substation and converter station is informed by the FRA. All National Grid substations are designed to provide resilience to a level equivalent to the 1:1000-year annual risk of flooding plus allowance for climate change.
- 3.1.5 The Kent cable route is mainly located in an area of low flat ground within the Stour River catchment called the Minster Marshes, with a ground elevation of approximately +2mAOD. The topography across the site rises from approximately +1m at the eastern extent along the coastline to a high of approximately +11.00mAOD around the A256 Richborough Way, then gradually sloping back down to +2.00mAOD at the western extent of the alignment. The HVDC cable route is 1.47km from +8.49mAOD to +2.11mAOD at the western new substation and converter station platform

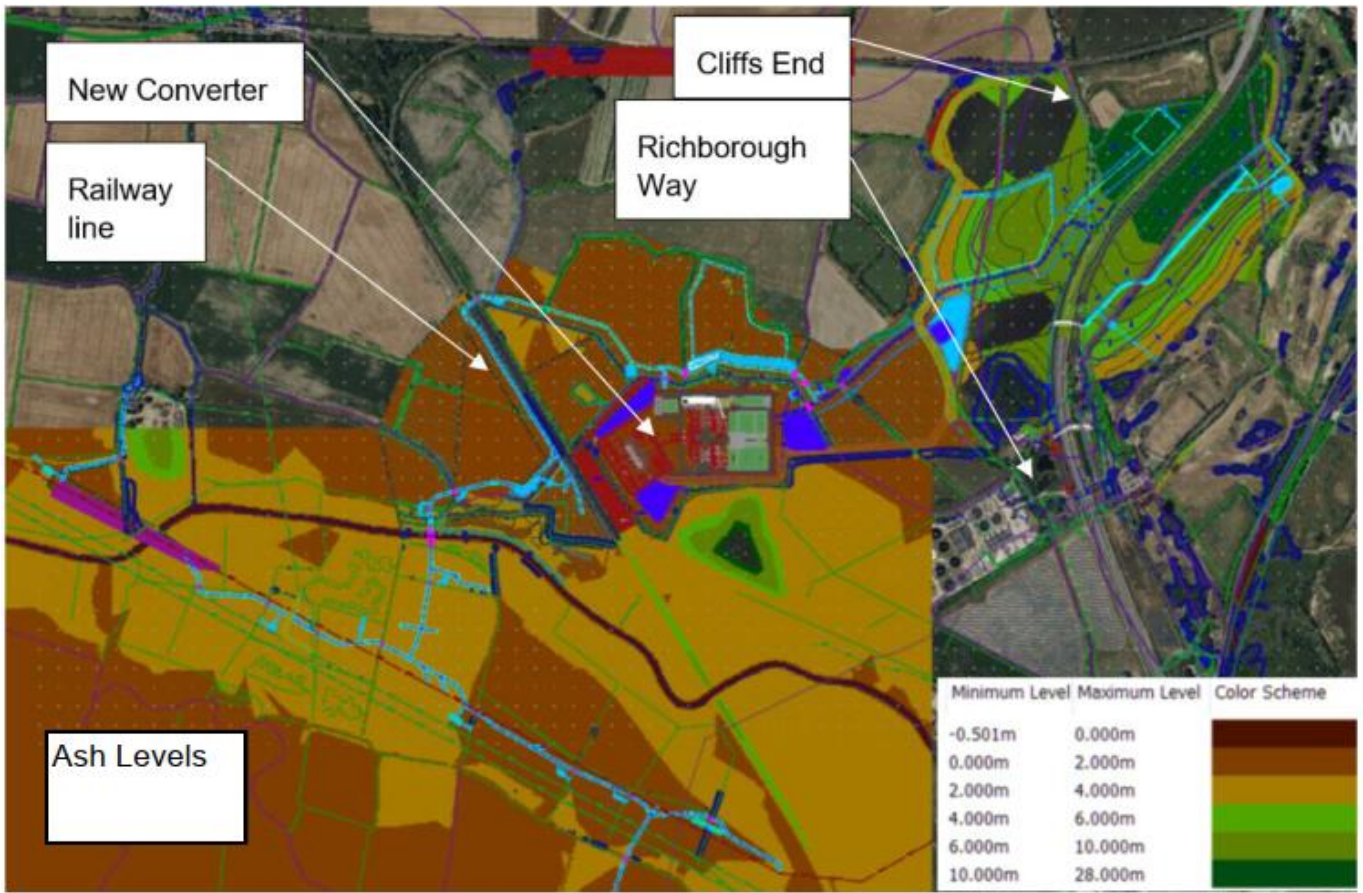

Plate 3.1 Existing Elevations

Source: OSTerrain 5 data (2023). Contains Mott MacDonald data (2024).

3.2 Existing Topographical Survey taken during 2023

- 3.2.1 An assessment of the available topography levels of all affected watercourses by the new outfalls has been undertaken to determine the minimum FFL of the platforms (substation and converter station) to provide a gravity connection from the platforms to the adjacent watercourses.
- 3.2.2 The FFL of the platforms is defined by the topography of the site, and it is influenced by the drainage of the platform:
 - If the site is in a risk of flooding area a minimum FFL is set to avoid flood risk.
 - All drainage within the platform must drain by gravity into the discharge point. The discharge point must be identified early stages to ensure the drainage can discharge by gravity according to the FFL of the platform defined in the FRA.
- 3.2.3 A preliminary pipeline design has been carried out in Appendix A to inform about the required Finished Floor Level of the new converter station and substation. This will provide an update of the maximum overall height of the scheme to inform the wider design and consenting process.

4. Existing Hydrology

- 4.1.1 The proposed Kent cable route is mainly located in an area of low flat ground within the Stour River Catchment.
- 4.1.2 The Stour has five main tributaries draining the clay headwaters which meet in the large urban area of Ashford. The river then flows through rural chalk downlands into Canterbury where the channel is highly modified with flood defences, sluices, gates and mills controlling the flow. Downstream of Canterbury, the river enters the tidally influenced Lower Stour area and flows through the internationally significant wetland habitat areas of Stodmarsh and Hacklinge Marshes, before flowing out into Pegwell Bay. The proposed cable route is under the management policies of the Sandwich Bay (Policy 3), as described by River Stour Catchment Flood Management Plan 2009 as “Areas of low to moderate flood risk where we are generally managing existing flood risk effectively” .

Plate 4.1 Sub-areas and Flood Risk Management Policies for River Stour

Map 3. Sub-areas and flood risk management policies.

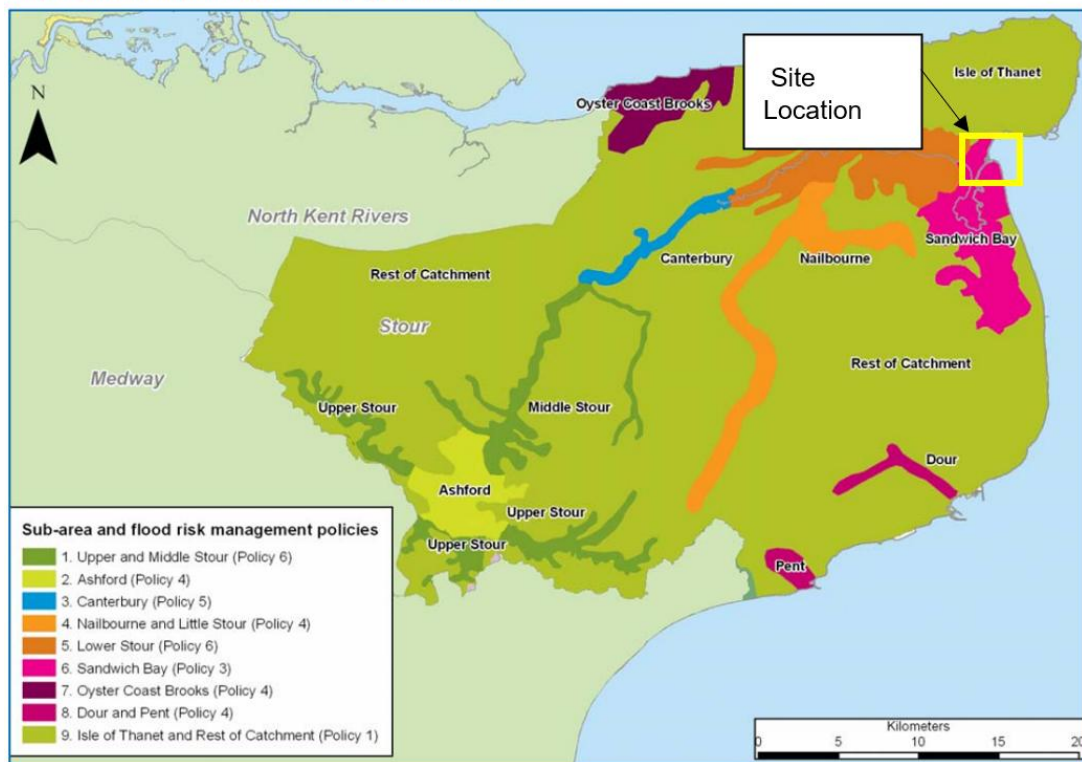

Plate 4.1 Sub-areas and Flood Risk Management Policies for River Stour

Source: River Stour Catchment Flood Management Plan 2009.

4.2 Watercourses

- 4.2.1 Appendix B shows all existing watercourses affected by the proposed route. The legend indicates the different rivers as per ownership:
- Main Rivers are rivers, larger streams and smaller watercourses of strategic drainage importance regulated by the Environment Agency.
 - Ordinary Watercourses are rivers, streams, ditches, drains, sluices and so on which do not form part of a main river. There are two types of Ordinary Watercourses: those regulated by an Internal Drainage Board (IDB), which are usually named; and those that are regulated by the Lead Local Flood Authority (LLFA), which are usually unnamed.
- 4.2.2 The Kent cable route crosses multiple water features including rivers, watercourses, and ditches. An assessment of the cable route has been undertaken to locate crossings of Main Rivers and Ordinary Watercourses, and to identify the relevant regulatory body for each Ordinary Watercourse. Watercourse crossings are outlined in **6.3.1.4.A ES Appendix 1.4.A Crossings Schedules [APP-089]**.
- 4.2.3 The site area to the north of the River Stour, labelled 'Minster Marshes' on OS mapping, generally comprises arable agricultural land. A network of drains and streams bound the fields, including Minster Stream and Western Monkton Stream which drain southwards to the River Stour. Marsh Farm and a Sewer Treatment Works (STW) are located immediately north of the River Stour. There are several drainage ditches in the Minster Marshes which bound and transect the cable route, the largest being Minster Stream. The Minster Marshes is a waterlogged area, for the following reasons:
- The non-free-draining nature of much of the underlying rock such as Thanet Formation.
 - The low elevation of the area compared to sea level
 - The tidal influence from the coast.

Main Rivers

- 4.2.4 The proposed cable route sits under the two river basin management plans: the Stour Marshes Operational Catchment and the Monkton and Minster Marshes River Catchment.
- 4.2.5 The Environment Agency (EA) Statutory River affected by the proposed cable route is the Stour River. The Stour River is affected by a temporary access road to the new overhead line (OHL) connection, where a new temporary bridge crossing is proposed as agreed with the EA.

Ordinary Watercourses under the Internal Drainage Board (IDB)

- 4.2.6 The River Stour (Kent) Internal Drainage Board (IDB) is the internal drainage district that interfaces with the proposed Kent cable route.
- 4.2.7 The Minster Stream IDB watercourse passes through the sites proposed for the converter, substation and laydown areas. The latest topographical data received in December 2023 shows the base and top elevations of the Minster Stream IDB watercourse. This watercourse is 2m deep and sits on a flat base elevation of +0mAOD.
- 4.2.8 is a map of the River Stour (Kent) Drainage District (shaded blue). EA maintained Main Rivers are shown in red, River Stour IDB maintained watercourses in blue, landowner

maintained watercourses in pink. There are numerous streams and drainage ditches feeding into Minster Stream from the north and south located along field boundaries. In a couple of locations these are identified to pass underground for short lengths.

Plate 4.2 River Stour Drainage District

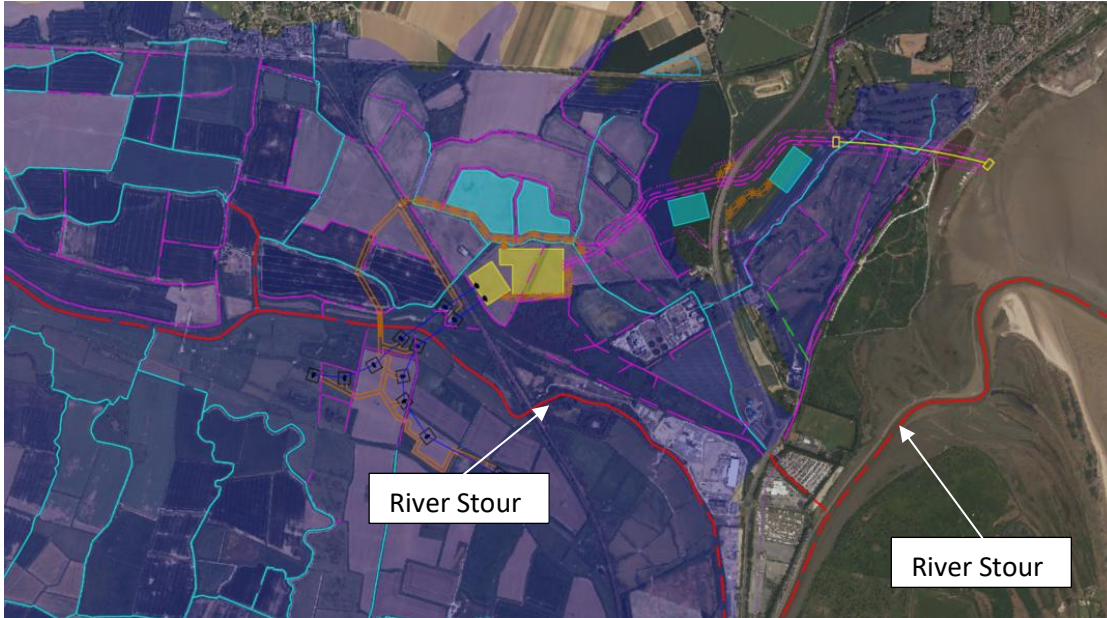

Plate 4.2 River Stour Drainage District

Source: River Stour (Kent) IDB (2023).

Drainage Ditches

4.2.9 For Ordinary Watercourses in Kent outside an IDB area, the relevant authority is Kent County Council (KCC) as the LLFA. Ordinary Watercourses and ditches affected by the cable route have been identified based on Ordnance Survey mapping data.

Summary of Watercourse Crossings

4.2.10 To identify existing watercourses affected by the cable scheme, OS Mapping, Aerial mapping, Openstreet mapping, and the Magic Map Website were used as data sources. The topographical survey by 3D Engineering Surveys dated November 2023 includes bottom of ditch and top of embankment of many watercourses affected by the scheme, but not all have been surveyed.

4.2.11 A summary of the watercourse crossings identified is presented in Table 4.1

Table 4.1 Cable route watercourse crossings

Main River	Ordinary watercourse
------------	----------------------

Environment Agency	River Stour Internal Drainage Board
3	46

Source: Sea Link Cable Crossing Schedule, SEAL-MMD-SEAL-REG-ENG-0081, Mott MacDonald (2024).

4.3 Lakes and Reservoirs

4.3.1 Ponds are generally common because of the underlying nature of the Thanet Formation which has high groundwater. Two reservoirs are located immediately north of the site area adjacent to Marsh Farm Road, south of Minster and the railway line.

4.4 Existing Sewers

4.4.1 The immediate area surrounding the site predominantly comprises agricultural land becoming more industrialised to the south with the existing Weatherlees Hill Wastewater Treatment Works (WTW) located approximately 275m south of the proposed cable route.

4.4.2 Sewer records obtained from Southern Water indicate that sewers are present near to the cable route. The HVDC cable route alignment intersects with a Southern Water sewer at approximately Ch410m from the landfall point, under Sandwich Rd where the proposed HDD crossing is located. This sewer connects to the Weatherlees Hill Wastewater Treatment Works.

4.4.3 All known utilities crossings as included in the Sea Link Cable Crossing Schedule, **6.3.1.4.A ES Appendix 1.4.A Crossings Schedules [APP-089]**.

4.5 Existing Field Drainage

4.5.1 Locations and details of existing field drainage systems are unknown at this stage.

4.5.2 The Rural Sustainable Drainage Systems (RSuDS) by the EA states the average drain depth is 0.9m approx. where the average drain spacing drain is between 15-30m approx. A high concentration of field drainage is predominant on clay soils, with the majority of schemes using mole ploughing drainage techniques. The Kent cable route geology is predominantly Tidal Flat Deposits (clay and silts) with shallow groundwater, which is evidenced by the many watercourses in the Minster Marshes area. Therefore, there is a high probability of field drainage in the agricultural lands being affected by the Kent proposal.

4.5.3 In the case of field drainage encountered on site, a typical drainage layout could be expected. A field can contain a combination of different layouts or be drained irregularly, depending on the surface slopes across the field. If smaller fields have been merged into one, the outfalls may be found at the low points of each original field and not the current field. Some typical layouts are presented in Plate 4.3.

Plate 4.3 Typical land drainage layouts

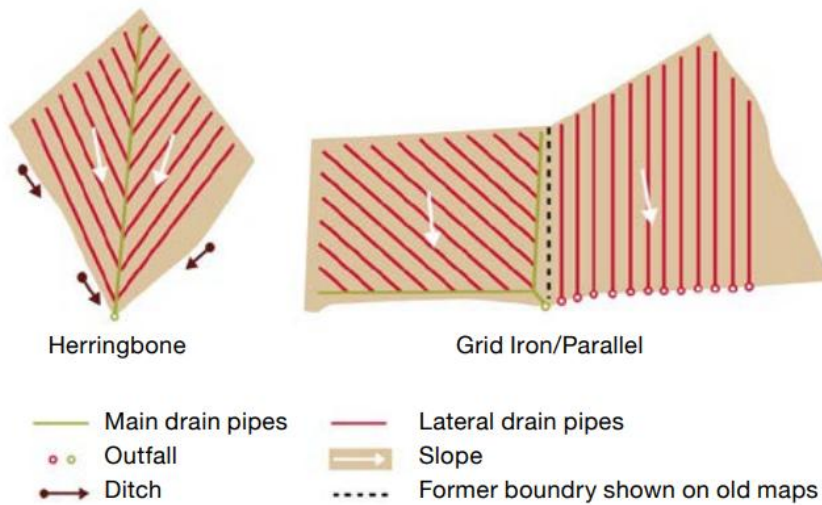

Source: Field drainage guide by Agriculture and Horticulture Development Board (AHDB) (2022).

4.6 Flood Zones

- 4.6.1 The Flood Risk Assessment document assesses the impact of the proposed development on flood risk from surface water, fluvial, coastal or groundwater sources, or any changes to flood risk in the surrounding areas affected by the Sea Link project. To produce this drainage strategy, a review of the EA flood risk mapping has been considered to ensure that the proposed development does not increase flood risk to the site or elsewhere and where practicable reduces flood risk over the lifetime of the development. Mapping of flood risk is provided in **6.4.2.4 ES Figures Kent Water Environment [APP-263]**.
- 4.6.2 The River Stour Catchment Flood Management Plan 2009 (EA) indicates the cable route lies in a sub-area and flood risk management policy and Sandwich Bay (Policy 3):
- “Sandwich Bay (Policy 3) defined as areas of low to moderate flood risk where we are generally managing existing flood risk effectively.”
- 4.6.3 The Sandwich policy indicates that there is risk of tidal flooding from overtopping of sea defences as well as from storm surges moving up the Stour. The tidal flood risk in this area has been assessed under the Pegwell Bay to Kingsdown coastal defence strategy. The Stonar Cut provides a ‘short cut’ for the Stour, allowing fluvial floodwater to bypass the Sandwich area and reach the sea. This structure is crucial in protecting Sandwich.
- 4.6.4 The River Stour Catchment Flood Management Plan 2009 makes decisions on how and when the water on the marshes upstream of Sandwich marsh should be moved around and managed through the Sandwich Bay to Hacklinge Marshes Water Level Management Plan (WLMP).
- 4.6.5 The majority of the HVDC cable route corridor is not identified to be at risk of river and coastal flooding except for the section through St Augustine’s Golf Club where the flood risk category is Low risk (Flood Zone 2) with an area of High risk (Flood Zone 3) to the

east, parallel with Sandwich Road. This is where the onshore cable route lands from the offshore cable.

- 4.6.6 Jointing bays are underground structures constructed at intervals along the onshore cable route to join cable sections and facilitate cable installation into the buried ducts. All jointing bays along the cable route will be protected from groundwater ingress. Mitigation measures will be introduced to mitigate flood risk during the construction phase of these elements in the Construction Environmental Management Plan (CEMP) **7.5.3 Outline Onshore Construction Environmental Management Plan [APP-340]**, that has been developed to avoid, minimise or mitigate any construction effects on the environment.
- 4.6.7 The Converter Station and Substation site is not identified to be in an area at risk of river and coastal flooding. The area north of the Stour River benefits from flood defences. Only the area of the proposed OHL connection with the existing OHL is within undefended Flood Zone 3.
- 4.6.8 The HVDC cable route is not identified as an area at risk of surface water flooding, except for the area where the cable route sits within St Augustine's Golf Club.

5. Existing Ground Conditions

- 5.1.1 The existing ground conditions are described in the DCO application in **6.3.3.5.C ES Appendix 3.5.D Ground Investigation Report – Kent [APP-171]**.
- 5.1.2 A review of the report “Geotechnical and Geo-environmental Preliminary Risk Assessment (Desk Study) Report – Richborough” (SEAL-MMD-SEAL-ENG-REG-0057, Mott MacDonald, 2022) has identified the following information relevant to drainage strategy of the development.
- 5.1.3 Following the recent Ground Investigation (GI) report during end of 2023, this Section is revised, the Factual Report on Preliminary Ground Investigation (Structural Soils Ltd, 2024, Report No.: 563607-01 (03)).

5.2 Geology

- 5.2.1 The British Geological Survey (BGS) 1:50,000 mapping indicates the site is underlain by the Thanet Formation with a varying thickness of Tidal Flat Deposits which is predominantly clay and silt. The cable route incoming from the sea passes through Pegwell Bay Country Park that consists of Beach and Tidal Flat Deposits, of sand, silt and clay. In localised areas, where there is no superficial cover the cable route will lie within the Thanet Formation.
- 5.2.2 The following high-level summary of the anticipated geology is taken from the Geotechnical and Geo-environmental Preliminary Risk Assessment (Desk Study) Report (EAL-MMD-SEAL-ENG-REG-0057, Mott MacDonald, 2022):
- 5.2.3 **Superficial geology**
 - Beach and Tidal Flat Deposits are only expected within the vicinity of the offshore HDD section at landfall.
 - Head (formally Head Brickearth): No outcrops mapped on site but may possibly underlie the Tidal Flat Deposits in places.

5.2.4 **Bedrock Geology**

- The bedrock geology comprises the Thanet Formation (sand, silt and clay), which is shown to outcrop around Marsh Farm to the west of the substation/ converter station site and also to the east along the route of B256 Richborough Way. The Thanet Formation overlies the Margate Chalk Member.
- Seaford Chalk Formation.

5.2.5 **Made ground**

- Made Ground is not shown to be present on the geological map, however it is known that Made Ground will be present in the vicinity of Stonelees Golf Club which has been built up with reworked ground as part of the landscaping of the golf course.

5.2.45.2.6 Refer to Appendix C for the BGS Mapping with the cable route.

Permeability

[5.2.55.2.7](#) Permeability of the ground influences whether the drainage strategy for the scheme can incorporate infiltration as a method for disposal of surface water flows.

[5.2.65.2.8](#) The nature of the superficial deposits of the Kent area indicates that no infiltration into the ground will be feasible for the future design of the scheme in Kent.

5.3 Contaminated Land

5.3.1 Contamination risks in the surrounding area relate to the potential for sub-surface migration of contaminants onto the site from off-site historical landfill, and possible spillages/leakages of chemicals associated with Richborough Power Station and sewage works within 500m of the scheme.

5.3.2 Risks to controlled waters (groundwater and surface water) were assessed as moderate/low to moderate due to their proximity to the site and shallow groundwater likely to be in hydraulic continuity with the surrounding water bodies; copper, nickel and zinc were identified in one of the groundwater samples. It is recommended that groundwater will be monitored during works of the proposed scheme.

5.3.3 The potential source of contamination in the made ground and superficial deposits is from ground gases, heavy metals, and hydrocarbons. This is moderate to low/moderate contamination risk.

5.3.4 BH9 in the Stonelees Golf Club contained asbestos.

5.4 Groundwater and Source Protection Zones (SPZ)

5.4.1 The Kent cable route geology is predominantly Tidal Flat Deposits (clay and silts) with shallow groundwater, which is evidenced by the many watercourses in the Minster Marshes area. Shallow groundwater is considered likely to be encountered in a number of areas within the development due to the hydraulic continuity with the surrounding water bodies.

5.4.2 The Factual Report on Preliminary Ground Investigation (Structural Soils Ltd, 2024 Report No.: 563835-01 (03)) includes groundwater monitoring.

5.4.3 The development design will need to account for fully saturated ground, and the need to dewater groundwater from the installation of any infrastructure required to be built in dry conditions.

6. Surface Water Drainage Design Strategy

6.1 Overview

6.1.1 This section gives the detailed drainage design strategy for each component of the scheme. These principles have been followed to produce preliminary drainage design. Details are summarised in Appendix A and drawings showing the design can be found in the Appendix B.

6.2 Design Guidance and Policy

6.2.1 The drainage strategy for the proposed development has been developed based on the following guidance:

- Flood and Water Management Act 2010¹²
- National Planning Policy Framework (NPPF25)¹³
- The SuDS Manual (C753)¹⁴
- Generic Electricity Substation Design Manual for Civil, Structural and Building Engineering:
 - Section 01 Oil Containment (TS 2.10.01);
 - Section 09 Site Drainage (TS 2.10.09);
 - Section 13 Flood Defences for Electricity Substations (TS 2.10.13).
- Local SuDS Guidance¹⁵.
- Kent County Council Drainage and Planning Policy Statement 2019

6.2.2 The NPPF25 guidance outlines how the use of appropriate sustainable drainage systems, or SuDS, can better manage risk of surface water flooding, as well as improving water quality by reducing the amount and rate of water flow by infiltration, storage, attenuation, and slow conveyance.

6.2.3 The design proposed seeks to improve the local run-off profile using systems that can either attenuate run-off or reduce peak flow rates on the existing flood profile.

6.2.4 The Department for Environment, Food and Rural Affairs Sustainable Drainage Systems Non-statutory technical standards for sustainable drainage systems expands on this:

- The drainage system must be designed so that, unless an area is designated to hold and/or convey water as part of the design, flooding does not occur on any part of the site for a 1 in 30-year rainfall event.

¹² Flood and Water Management Act 2010 (2010). [Online]. <https://www.legislation.gov.uk/ukpga/2010/29/introduction> [Date Accessed: September 2025].

¹³ Ministry of Housing, Communities and Local Government (2021). [Online]. Available at: <https://www.gov.uk/government/publications/national-planning-policy-framework--2> [Date Accessed: September 2025].

¹⁴ CIRIA, The SuDS Manual (2015)

¹⁵ https://www.kent.gov.uk/_data/assets/pdf_file/0007/23578/Masterplanning-for-SuDS.pdf

- The drainage system must be designed so that, unless an area is designated to hold and/or convey water as part of the design, flooding does not occur during a 1 in 100-year rainfall event in any part of: a building (including a basement); or in any utility plant susceptible to water (e.g., pumping station or electricity substation) within the development.
- The design of the site must ensure that, so far as is reasonably practicable, flows resulting from rainfall in excess of a 1 in 100-year rainfall event are managed in exceedance routes that minimise the risks to people and property.

6.2.5 The Environment Agency requires that there should be no increase in the rate of surface water emanating from a newly developed site above that of any previous development. Furthermore, it is the joint aim of the Environment Agency and Local Planning Authorities to actively encourage a reduction in the discharge of storm water as a condition of Approval for new developments.

6.2.6 **Permanent Works**

6.2.66.2.7 The permanent works include the normal features of a substation and converter station: transformers, buildings, internal roads, car parks and external access roads. The substation and converter station design life is 50 years (20 years first life maintenance).

6.2.76.2.8 The drainage criteria for permanent work will follow the design stated on the National Grid design document TS 2.10.13:

- 1 in 30-year rainfall event – no flooding on site.
- 1 in 100-year rainfall event – no flooding on operational areas of the site (car parks may flood in this scenario).
- In both 1 in 30-year and 1 in 100-year scenarios, the design shall ensure that excess runoff from the drainage system does not impact adjacent third-party land.
- Where discharge consents or downstream capacity restrictions are in place the design shall restrict flows and incorporate attenuation to achieve the requirement.

6.2.9 **Temporary Works**

6.2.86.2.10 Temporary haul road, cable swathe and construction compound works are to be installed for approximately 5 years (which could vary as the construction stage develops).

6.2.96.2.11 As per CIRIA C532 Control of water pollution from construction sites for temporary works, a 1 in 5-year return period would be appropriate in most circumstances. However, specific design criteria would have to be agreed with the relevant environment protection authority during the drainage stakeholder engagements.

6.2.106.2.12 National Grid does not provide specific guidance on the design criteria for temporary works. Consequently, the design criteria for flows from the proposed temporary works, including climate change allowance, has been agreed with the River Stour Internal Drainage Board (IDB) during drainage stakeholder engagements as indicated in Appendix D of this report.

6.2.116.2.13 The 1 in 30-year return period storm event will be accommodated for the temporary construction stage drainage scheme with no need for climate change allowance.

Climate Change

6.2.126.2.14 The site is located in the Stour Management Catchment. The Environment Agency provides guidance on percentage uplift to peak rainfall intensities that should be allowed for in new developments to account for the effects of climate change as per .

6.2.136.2.15 The proposed climate change allowance for the permanent development drainage scheme is 45%, matching the “Upper end allowance” parameter. The flood risk vulnerability classification established for a substation is described as essential infrastructure, for which this parameter should be used. The 2050s epoch is used for the anticipated design life of 50 years (as per National Grid TS 2.10.13 – Flood Defences for Electricity Substations).

6.2.146.2.16 The proposed climate change allowance for the construction stage drainage scheme has been agreed with the River Stour IDB during a drainage stakeholder meeting. Whilst an allowance for climate change is not required by River Stour IDB for the design of temporary drainage features, it was considered appropriate to apply a 20% climate change allowance in the current drainage design due to the risk of flooding in the Minster Marshes area.

Plate 6.1 Climate change uplift allowances

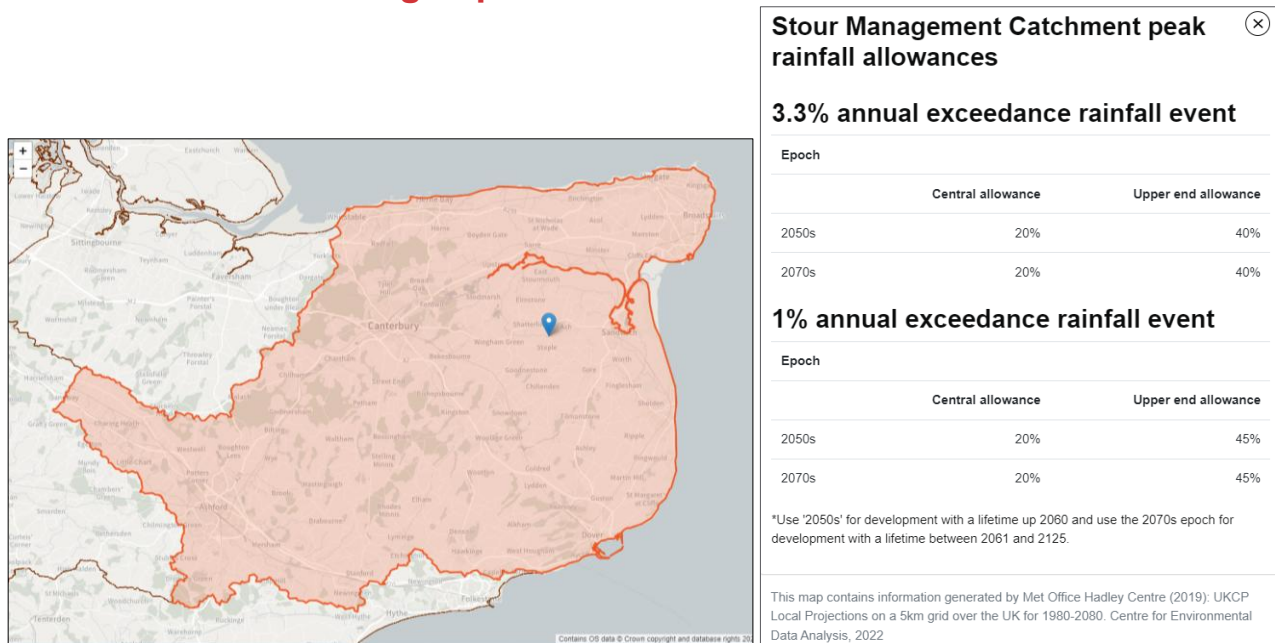

Plate 6.1 Climate change uplift allowances

Source: Environment Agency¹⁶.

6.3 Runoff Destination

- 6.3.1 It should be acknowledged that the satisfactory collection, control and discharge of storm water is a principal planning and design consideration.
- 6.3.2 The NPPF states that for new developments, the best way of reducing flood risk within the development is to:

¹⁶ <https://environment.data.gov.uk/hydrology/climate-change-allowances/rainfall?mgmtcatid=3035>

- Control the water at source through sustainable drainage system (SuDS).
 - Consider exceedance flow route when the capacity of the drainage system is exceeded.
- 6.3.3 SuDS should mimic natural drainage and reduce the amount and rate of water flow by:
- Infiltration into the ground,
 - Holding water in storage areas, and
 - Slowing the flow of water.
- 6.3.4 The design will meet the following discharge hierarchy (with acceptable justification for moving between levels) by the CIRIA C753 SuDS manual:
1. infiltration to the maximum extent that is practical – where it is safe and acceptable to do so
 2. discharge to surface waters
 3. discharge to surface water sewer
 4. discharge to combined sewer (last resort)
- 6.3.5 The design allows for full attenuation and infiltration or discharge of the runoff from the proposed temporary and permanent works, in line with the design requirements outlined within Section 6.2 of this report. However, there are opportunities within both the temporary and permanent phases of the project to reuse collected water on the site or within the near vicinity, to reduce the quantity of discharged water. Use during construction could include trenchless drilling fluid, dust suppression, wheel washes or use within the welfare units as a non-potable water source. Use during the operational phase could include irrigation, top up of the fire water tank or use within welfare facilities. The Applicant has also held early discussions with interested parties who may benefit from the water being used as a source of irrigation for agricultural land in the near vicinity to the project. The Applicant will continue to explore these opportunities as the detailed design develops.

6.56.4 Management of Extreme Rainfall and Flooding

6.5.16.4.1 The proposed surface water drainage strategy is to replicate as closely as possible the natural runoff characteristics of the existing site, intercepting all flows from the permanent works and temporary works into attenuation basins prior to discharging into the nearest watercourse.

Post-Development Discharge Rates

6.5.26.4.2 Following the discharge hierarchy of the SuDS guidance described in the previous section, and since infiltration to the ground is unlikely to be feasible, it is proposed to discharge to the closest watercourse.

6.5.36.4.3 Discharge rates to receiving watercourses have been based on initial discussions with the River Stour IDB. The proposed discharge rate is 2l/s/ha, as this is considered the minimum viable rate of discharge with modern flow control techniques. During the initial

discussion, the high risk of flooding in and around the Minster Marshes area was highlighted by the IDB.

[6.5.46.4.4](#) To manage the flood risk across the site, an assessment of the pre-development discharge rates and the proposed catchment areas was carried out to assess the most suitable post-development discharge rates for the Kent scheme. Discharge rates to receiving watercourses are based on the estimated 'greenfield' run-off rate (Qbar) for the undeveloped site in accordance with Kent County Council guidance.

[6.5.56.4.5](#) Appendix A shows the proposed discharge rate for each attenuation basin.

Estimated Storage Volumes

[6.5.66.4.6](#) The MicroDrainage Source Control Module has been used to provide an initial estimate of attenuation storage volume that would be required to limit run-off from the site to the proposed post-development discharge rate as shown in Appendix A.

[6.5.76.4.7](#) The method to produce the drainage calculations has used the following input data:

- The proposed catchment areas have been extracted from the scheme plans and assigned the appropriate design criteria (for temporary and permanent design).
- A catchment is an area with a natural boundary (for example ridges, hills or mountains) where all surface water drains to a common channel to form rivers or creeks. The drainage catchments are established by the creation of an alignment along the centre line of the cable route. This alignment incorporates the Lidar and OS terrain data. The alignment identifies high points and low points along the route. Catchments are also bounded by existing roads, railway lines and watercourses.
- Catchment descriptors have been imported from the UK Centre for Ecology and Hydrology (CEH) Flood Estimation Handbook (FEH) for three catchments., see Appendix C. This FEH data has been used to obtain Qbar in accordance with KCC. FEH Catchment descriptors used are listed below:
 - FEH Catchment Descriptors: 631000_163000 (Main Catchment)
 - FEH Catchment Descriptors: 633650_162400 (East Catchment)
 - FEH Catchment Descriptors: 631200_162650 (South Catchment)
- The discharge rates have been associated to each catchment area according to the impermeable area of each catchment following the criteria for the post-development discharge rate Qbar.
- Point descriptors for runoff rate estimation have been imported from the UK Centre for Ecology and Hydrology (CEH) Flood Estimation Handbook (FEH) in three locations to provide representative rainfall prediction throughout the scheme, see Appendix C. FEH data is used to estimate the rainfall depths and volumes in accordance with the requirements of National Grid guidance TS 2.10.09 and KCC Local SUDS Guidance. FEH point rainfall used for the rainfall is listed below:
 - FEH point rainfall: 630997_163011 (Main Catchment)
 - FEH point rainfall: 633384_162747 (East Catchment)
 - FEH point rainfall: 631199_162651 (South Catchment)

Proposed Surface Water Drainage Networks

The strategy of the drainage is established via three independent networks as per the quality of the water to be collected:

Table 6.1 Independent networks forming drainage strategy

Temporary “dirty water” drainage network	Temporary/Permanent “clean water” drainage network	Permanent surface water drainage network
Runoff from temporary features during the construction stage is considered “dirty water” due to the possibility of contamination with oils and silts. The design will include pollution controls and treatment, and the contractor will implement suitable mitigation measures to manage this risk during construction.	Greenfield runoff from existing overland flows that are intersected by the substation, compound platform, access roads, cable swathe and construction compounds is considered “clean water”. These will be intercepted by swales to discharge to the nearest watercourse without flow restriction.	Runoff from the permanent features considers surface water drainage of the substation plot, including transformers, buildings and internal roads, and the external access road.

Temporary Works

[6.5.86.4.8](#) It should be noted that all temporary features described in this section will be removed post scheme construction and reinstated to the previous agricultural land use.

Construction compound sites

[6.5.96.4.9](#) Construction compounds associated with the onshore works may include areas of hardstanding, lay down and storage areas for construction materials and equipment, areas for vehicular parking, welfare facilities, wheel washing facilities, workshop facilities, and temporary fencing or other means of enclosure. The construction compounds will utilise subbase storage as part of attenuating the flows. Construction compounds have been assumed to be 75% impermeable with their gross site areas. Soil bunds surrounding the compounds have been excluded from the compound drainage design.

[6.5.106.4.10](#) The flows originated for the runoff intercepted by the construction compounds will be attenuated using external attenuation basins and, the subbase of the construction compounds will be used as storage as part of attenuating the flows.

[6.5.116.4.11](#) Any fuelling areas within the compound will be bunded and managed separately.

Table 6.2 Overall % PIMP (Percentage of Impervious Area) values for a typical cable construction layout

Individual catchment	Hardstanding areas (m²)	% PIMP
Road / parking / cabins	13337	100%
Type 3 gravel pavement: plant / fuel tank storage, crane platform	2699	30%
Laydown area: compacted soil	4185	20%
Spoil area: compacted soil	2279	20%
TOTAL	22500	70%

Plate 6.2 PIMP values for a typical cable construction layout

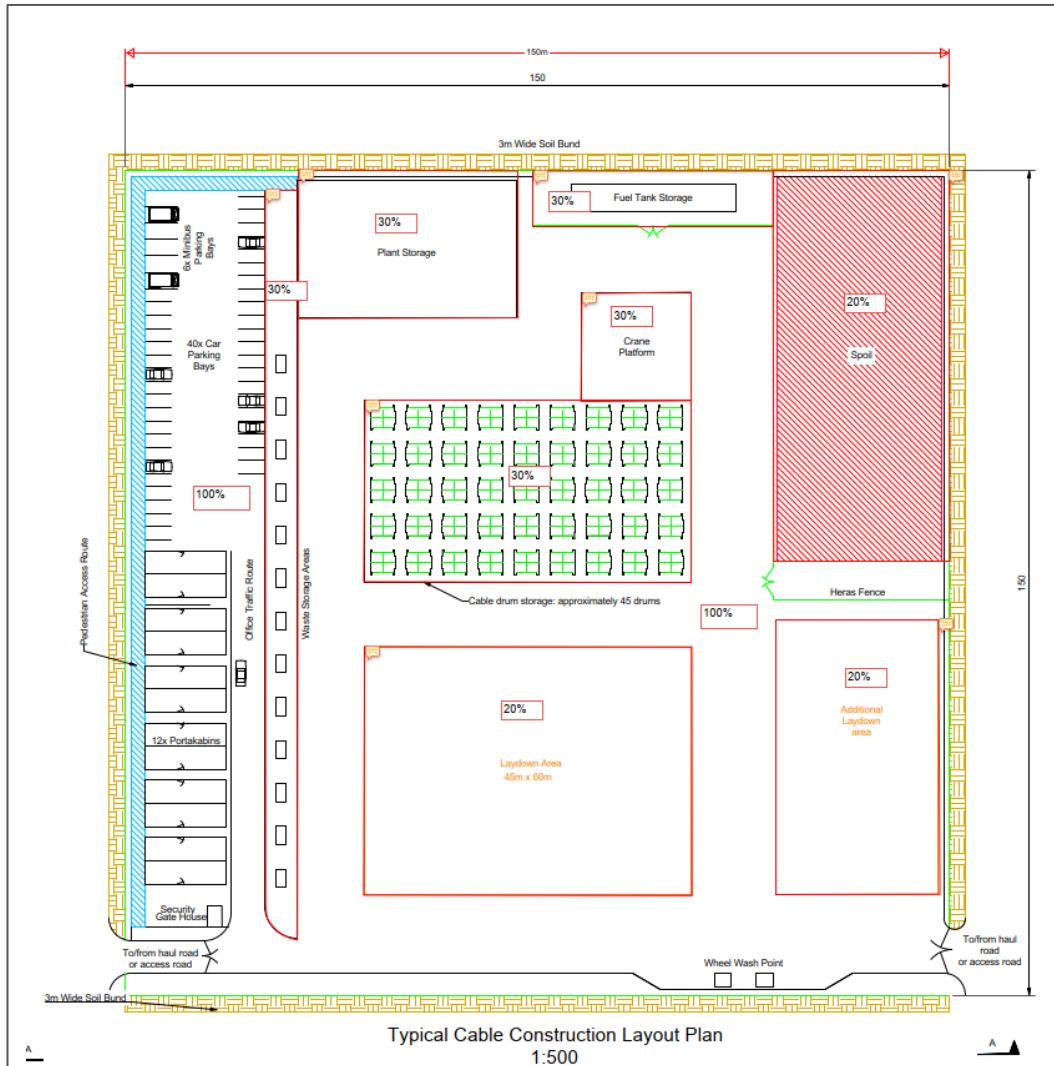

Plate 6.2 PIMP values for a typical cable construction layout

Haul Roads

[6.5.126.4.12](#) The haul roads run the length of the proposed cable route and are to be constructed from unbound granular material. There is potential for geogrid layers or other types of soil additives to be used for stabilisation. The haul road surface is considered 100% impermeable.

[6.5.136.4.13](#) The preliminary design considers the haul road to access the construction compound and haul roads within the cable route. Haul road impermeable catchment areas have been based on an average haul road width of 7m.

[6.5.146.4.14](#) It is proposed that a “dirty” channel drain along the edges of the haul road will collect runoff from the haul road and avoid any possible pollutants draining into the ground during construction of cable trenches. This channel drain will discharge into proposed attenuation basins which include a treatment element to clean anticipated pollutants from the road. In order to locate the proposed attenuation basins to drain the haul roads, the haul road has been subdivided into sections based on the existing longitudinal ground profile and anticipated low points along the route. Attenuation

basins have been sized based on these subdivisions and a further review will be required once the vertical geometry of the haul road has been confirmed, which may increase or decrease the sizes of basins required. The new attenuation basins discharge into existing watercourses via a control device to a reduced runoff rate.

6.5.156.4.15 _____ Dimensions of watercourse crossings were based on a topographical survey conducted by 3D Engineering Surveys Limited Dec 2023.

6.5.166.4.16 _____ Where a haul road crosses a watercourse, it is proposed that Ordinary Watercourses are culverted and Main Rivers are bridged, as agreed in the recent stakeholder meetings (see Appendix D).

HVDC routes during construction

6.5.176.4.17 _____ The proposed HVDC construction swathe is 40m width, see detail in **2.13 Design and Layout Plans [App-037]**. It contains a haul road 7m width centred in the swathe. The remainder of the proposed 40m wide construction swathe has been assumed to be permeable, but it is considered appropriate to add extra impermeable area for the cable swathe to reduce the impact of potential changes to surface water runoff and flood risk during construction. The additional impermeable area within the cable swathe is obtained from an assessment of the elements of the HVDC construction easement, resulting in the following assumption which has been used in the calculations:

6.5.186.4.18 _____ HVDC construction swathe has been assumed to be 25% impermeable with their gross site areas.

6.5.196.4.19 _____ The cable swathe will be bunded using the spoil excavated during the installation of the below ground cables. This has the potential to interrupt natural flow paths in some locations. Header drains will collect this “clean” surface water and direct it to the nearest watercourse.

6.5.206.4.20 _____ The cable trenches are located within the HVDC construction swathe. The cable trenches require drainage during construction only, when the ground on top of the trenches is not yet re-instated. Any water that could enter the trenches will be pumped to the attenuation basins that drain the construction swathe. Attenuation basins are proposed along the cable swathe.

Table 6.3 Overall % PIMP values for HVDC construction swathe

INDIVIDUAL CATCHMENT	HARDSTANDING AREAS WIDTH (M)	% PIMP
Haul road	7.0	100% (worst case assumed)
Cable trench	7.4	20% (assumed)
Topsoil / stockpiles	25.6	0%
TOTAL	40.0	25%

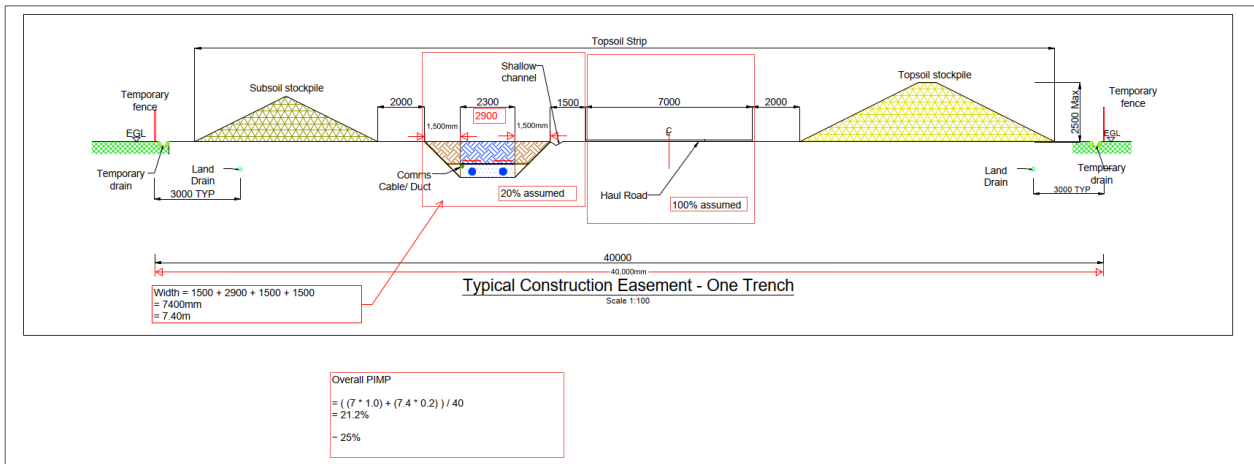

Plate 6.3 Overall % PIMP calculations for HVDC construction swathe

Jointing Bays and Transition Bay

[6.5-216.4.21](#) Jointing bays for HVDC cables are underground structures constructed at intervals along the onshore cable route to join sections of cable and facilitate installation of the cables into the buried ducts. Transition bays are underground structures at the landfall end of the cable route that house the joints between the offshore export cables and the onshore cables. Both are considered 100% impermeable.

[6.5-226.4.22](#) The jointing bays and transition bays have been added into the contributing impermeable area of the site. It is assumed that a sump will be provided to remove any water during construction. This sump will discharge into an attenuation basin connected to an existing ditch/watercourse.

[6.5-236.4.23](#) All jointing bays along the cable route which will be protected from groundwater and are not expected to contribute to any localised increased risk of flooding. Section 8.2.6 of this report establishes the water quality control measures of working in groundwater.

Overhead Line (OHL) and Pylons

[6.5-246.4.24](#) The proposed Kent route contains a new OHLs which will tie into an existing OHL. The overhead power lines are formed of pylons carrying (HVAC) transmission cables.

[6.5-256.4.25](#) During the installation of the pylons any runoff will be pumped out of the pylon working area and discharge into the basins proposed to drain the temporary access road that provide access to the new pylons.

Overland Flow Routes

[6.5-266.4.26](#) Greenfield runoff from existing overland flow routes will be intercepted by clean header drains and discharged to the nearest watercourse; this drainage is considered for the temporary and permanent cases:

- The temporary “clean water” drainage network captures the greenfield runoff from existing overland flow routes that intersect the works during construction stage (cables swathe and temporary haul roads) and will be intercepted by clean header drains and conveyed to the nearest watercourse without flow restriction.

- The permanent “clean water” drainage network captures the greenfield runoff from existing overland flow routes that intersect with the permanent features during operational stage (substation, converter station and permanent access roads) and will be intercepted by clean header drains and conveyed to the nearest watercourse without flow restriction.

6.5.276.4.27 The overland flows will discharge directly to the outfalls that drain the construction swathe, but they are not flow restricted, consequently the connection will be downstream of the proposed Hydrobrake or orifice flow control.

Permanent Works

Drainage in the permanent substation and converter station

6.5.286.4.28 The surface water drainage strategy for the new converter station and substation will be heavily informed by the Flood Risk Assessment (volumes to be quantified) and information fed in from the LLFA (KCC) and River Stour IDB.

6.5.296.4.29 This report considers estimating the volume of attenuation storage required for the scenario:

6.5.306.4.30 Partially permeable site (50% of the footprint permeable).

6.5.316.4.31 Runoff intercepted by the normal features of a substation and/or converter station: transformers, buildings, internal roads, car parks and external access roads will discharge into the proposed attenuation basins. Discharge from attenuation basins will be at a reduced runoff rate to the adjacent watercourse, the Minster Stream (IDB Watercourse).

6.5.326.4.32 The substation and converter station are partially permeable sites (50% of the footprint permeable), therefore this report assumes that the total hardstanding area for the drainage design is the 50% of the footprint of the substation and converter station platforms.

6.5.336.4.33 Substation and converter station platforms are formed by permeable stone surfacing that will be laid in accordance with National Grid Design Standards and will be constructed of a minimum 300mm deep unbound free draining subbase and a minimum 75mm top layer of stone chippings which will allow storage of storm water until it can infiltrate into the surrounding soil. The proposed platform is flat and will be graded back to tie with the surrounding ground and drains naturally into the ground. The runoff from the platform area will percolate through to the groundwater table or emerge as pluvial runoff in a similar manner to the existing pre-developed site.

6.5.346.4.34 Runoff from the permanent features (substation and converter stations platform) considers surface water drainage of the substation plot, including transformers, buildings and internal roads, and the external access road. The proposed surface water drainage system will improve the water quality of surface water runoff from the proposed development, which will ultimately outfall to existing watercourses. This will be done by using a treatment chain where each subsequent system within the proposed drainage network provides treatment to improve water quality, in line with National Grid Standard TS 2.10.01. All transformer bunds will drain into oil water separator tanks that discharge into the underground network. All transformers will have a totally sealed bund with a sump which has a bund water control unit to pump any water out. This will be directed through an oil separator to pick up any potential small levels of residual oil before being discharged into the main operational platform drainage system.

Table 6.47 Overall % PIMP calculations for the combined permanent substation and converter station

INDIVIDUAL CATCHMENT	HARDSTANDING AREAS (M2)	% PIMP
Roads / parking (tarmac)	13512	100%
Buildings	19081	100%
Type 3 gravel surface	82011	30%
TOTAL	114604	50%

Access roads and bellmouths

[6.5.356.4.35](#) Permanent access roads are to provide vehicular access to the converter station and substation sites. Access roads will have tarmac surface and they are 100% impermeable.

[6.5.366.4.36](#) Bellmouths are required to allow vehicles to turn safely at all locations where the temporary haul roads or permanent access roads interface with the existing public highway. There are a number of proposed bellmouths across the scheme of varying sizes which will be constructed from impermeable material (tarmac) to interface with existing public highways.

[6.5.376.4.37](#) Runoff from the access roads and bellmouths will be collected via filter drains/ditches along the edge and will be directed to a permanent attenuation basin that discharges to the closest watercourse. To locate the proposed attenuation basins to drain the main access roads, the road has been subdivided into sections based on the existing longitudinal ground profile and anticipated low points along the route. Access roads will drain into a filter drain system or the permeable platform; this will provide an adequate level of water quality treatment.

[6.5.386.4.38](#) When a permanent access road crosses a watercourse, culverting will be the required option for Ordinary Watercourses and bridging will be the option for Main Rivers as agreed in the stakeholder meetings (see Appendix D).

6.66.5 Management of Everyday Rainfall (Interception)

[6.6.16.5.1](#) The proposed SuDS features shall allow interception of the first 5mm of rainfall where possible, reducing runoff from the site into surface water or piped drainage systems. As stated in Section 5.4, shallow groundwater is considered likely to be encountered in a number of areas within the Kent Cable route development, resulting in interception through infiltration being minimal.

[6.6.26.5.2](#) The substation platform and laydown areas shall be constructed with permeable material, therefore offering interception of everyday rainfall. The permeable platform construction shall naturally retain runoff, where runoffs will be lost to the soils or the atmosphere.

[6.6.36.5.3](#) Filter drains with infiltration capabilities and swales, where possible, shall be placed along access roads and bellmouths to intercept everyday runoff. For swales to be suitable for interception they must comply the following as per Standard 2 of the National Standards for SuDS:

- A longitudinal gradient of less than 1:100;
- At least 500mm of suitable base material;
- A vegetated base surface area receiving runoff which is 5 times less than the impermeable area it serves, whether lined or unlined;
- When infiltration capability is greater than 1×10^{-6} m/s and the swale is unlined, it shall be assumed that the vegetated base area of the swale can contribute to an impermeable area of up to 25 times its size, and
- Interception shall not be deemed to have been provided for impermeable areas draining to an unlined swale within 5m from the swale outlet, unless the swale is flat and has a slightly raised outlet to create a temporary storage zone to encourage infiltration before runoff takes place.

[6.6.46.5.4](#) As per the Factual Report on Preliminary Ground Investigation (Structural Soils Ltd, 2024 Report No.: 563835-01 (03)) soakaway infiltration tests were conducted in trial pits and boreholes, along locations of the proposed onshore Kent development. Infiltration rates were not calculated for any of the tests as either there was no fall in test water level, or insufficient fall to justify a calculation of infiltration rate. Therefore, as infiltration is limited, everyday rainfall shall be captured, conveyed and stored within SuDs features, where runoff will be 'lost' to soils or the atmosphere.

[6.6.56.5.5](#) Proposed attenuation basins containing standing water do not offer any interception as per Standard 2 of the National Standards for SuDS, therefore other SuDS approaches have been used to comply with the interception of everyday rainfall, where infiltration rates allow.

[6.76.6](#) Proposed Drainage Features

Proposed Storage Basins

[6.7.16.6.1](#) Two types of basins are to be implemented – for construction phase and for operational phase.

- Operational attenuation basins only receive clean water from the permanent elements (substation, converter station and its access roads), and they do not have a designated volume for treatment.
- Temporary attenuation basins receive water from construction compounds and haul roads and have a designated treatment volume. For each basin there will be an area included for settlement of silts.

[6.7.26.6.2](#) For the preliminary design, a simplified spatial representation of the basins is provided as rectangular/circular areas. An additional buffer of 5m around the basins is included for access and maintenance and to allow for side slopes. The maximum depth of the basins is restricted due to the uncertainty of the groundwater table. Proposed basin depths vary from 0.5m to 1m, with 0.3m freeboard. An assessment of the groundwater and elevation of the site has been carried out to obtain the proposed basin depths. In areas where the topography is flat and there is proximity to a watercourse, the basin depth is limited to 0.5m to reduce the risk of groundwater flooding; the remaining areas where there is less risk of groundwater flooding a general 1m basin depth is proposed.

[6.7.36.6.3](#) The proposed attenuation basins will be designed with 1:3 slopes, vegetated, non-permeable geo-textile [or naturally](#) lined with an inlet forebay. This will provide treatment

of the runoff by allowing for settlement of silts, heavy metals and the removal of oxygen demanding material.

6.7.46.6.4 Where a proposed attenuation basin is used for temporary sediment control during construction, a settling basin or vegetated forebay within the main basin should be included to trap sediments. Sediment trap should be approximately 20% of the pool volume. Where an attenuation basin with a forebay element is retained for the permanent phase, the forebay will be removed at the end of the construction phase.

6.7.56.6.5 The general arrangement of the basin used during the construction phase is shown below:

Plate 6.4 Basin with Forebay detail

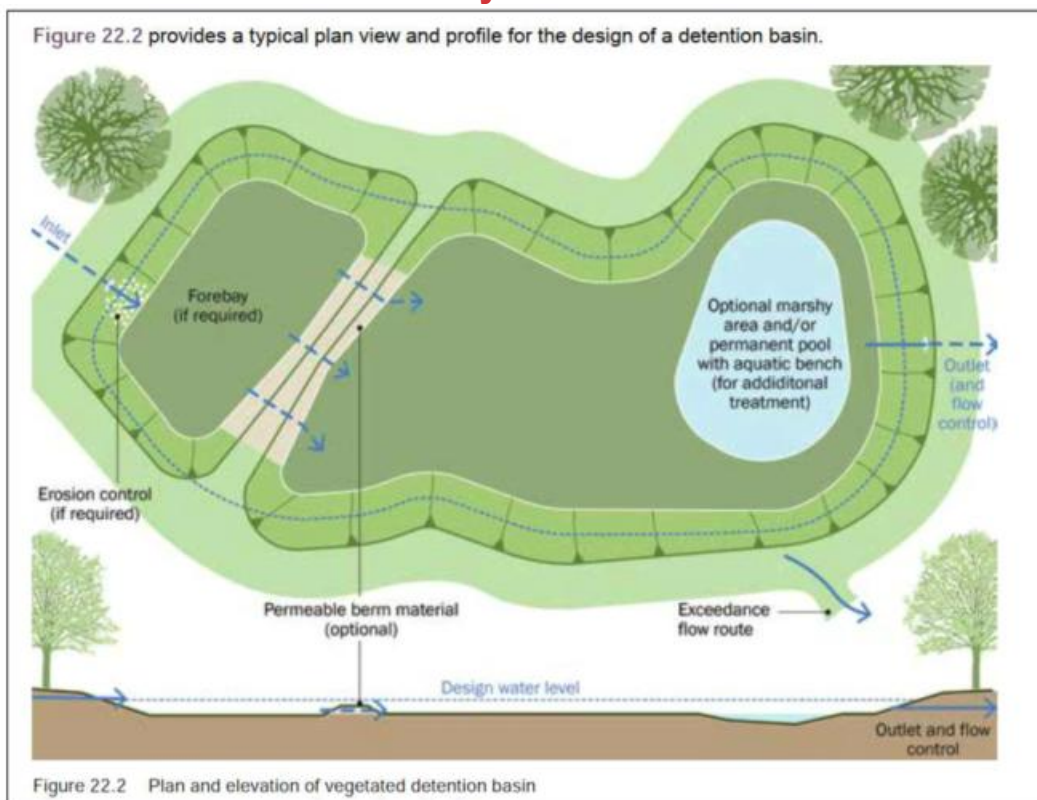

Plate 6.4 Basin with Forebay detail

Source: CIRIA C753.

6.6.6 The permanent attenuation ponds will be designed to be organic in shape and to be of value for riparian mammals by retaining an earth ledge and sloping bank above a shallow (e.g. minimum 10 cm) permanent water level. The ledge will be planted with emergent riparian vegetation. To reduce harm from deer, the permanently wet sections of the basins will be naturally lined (e.g. clay) rather than using artificial liners as the latter can be damaged by deer.

Header, Filter Drains and Swales

6.7.66.6.7 Header drains are to be used throughout the scheme to intercept clean surface water runoff coming from overland flows (they form part of the Temporary/Permanent “clean

water” drainage network. These drains limit flows from crossing the haul road, construction swathe or construction compounds and becoming silty. They run parallel to the haul roads and access roads; and around the perimeter of the construction compounds, converter station and substation compounds where required. The overland flows are assumed to be clean and therefore require minimal levels of treatment. Furthermore, the intercepted overland flows will be discharged into the nearest watercourse without restriction to flow.

[6.7.76.6.8](#) Filter drains or swales are to be used for drainage of the haul road and construction compounds. Any runoff intercepted within the permeable subbase of the construction compounds will be directed to the perimetral swales, as shown on Plate 6.5.

[6.7.86.6.9](#) They will collect dirty runoff from the haul road/construction compounds and discharge to the temporary attenuation basins along the route. Filter drains or swales used during the construction phase contain any surface water runoff of the compounds and haul roads, therefore preventing any potential pollutants, including silts and fines, entering the surrounding watercourses.

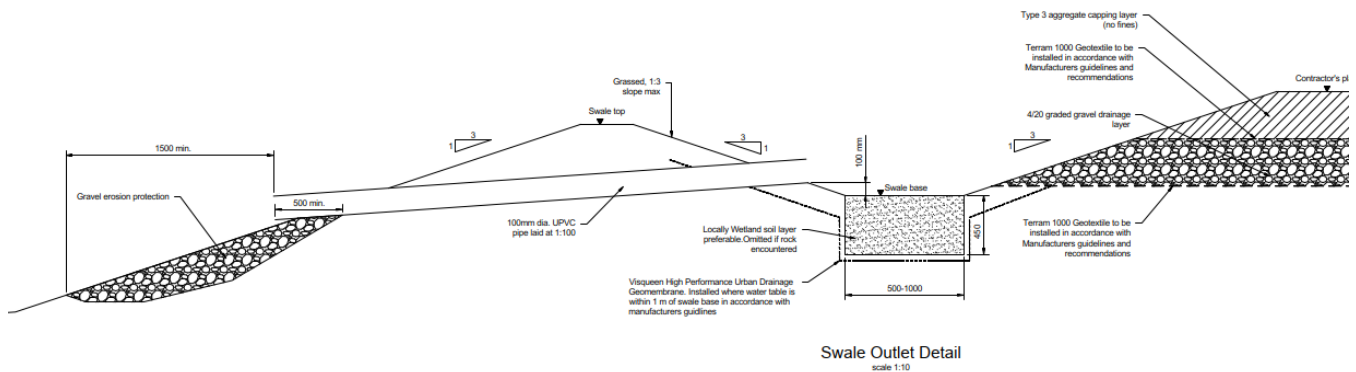

Plate 6.5 Proposed swale to intercept flows from the permeable subbase of the platforms

Source: Mott MacDonald.

Outfalls and Headwalls

[6.7.96.6.10](#) Topographical survey by 3D Engineering Surveys Limited provides the base of the watercourse elevation and top of the embankment of several ordinary watercourses where outfalls are proposed.

[6.7.106.6.11](#) In order to set up the Invert Level (IL) of each outfall a permanent water level is assumed on each watercourse. Therefore, the outfalls have a minimum vertical distance of 200mm from the (assumed) permanent water level to avoid outfalls being permanently submerged.

[6.7.116.6.12](#) When topographical survey is not available, LIDAR or OSTerrain5 is used to identify the minimum elevation of the outfalls. It assumed the elevation of the outfall is 0.5m below the elevation provided by the LIDAR or OSTerrain5 data.

[6.7.126.6.13](#) Appendix A includes recommendations of minimum invert levels for the proposed outfalls (permanent and temporary).

6.7.136.6.14 In accordance with TS 2.10.09, headwalls shall be provided at all positions where a drainage system discharges into open water. All outfalls to proposed attenuation basins are to be headwalls with a flap valve and all outlets from proposed attenuation basins are to be headwalls with a sluice gate. Scour protection should be provided for permanent and temporary outfalls. Outfalls should be angled at 45° to the water flow; small pipes (less than 300 mm diameter) can be at a maximum of 90° to the flow.

6.7.146.6.15 Water quality mitigations for discharging to watercourses are explained in Section 8.

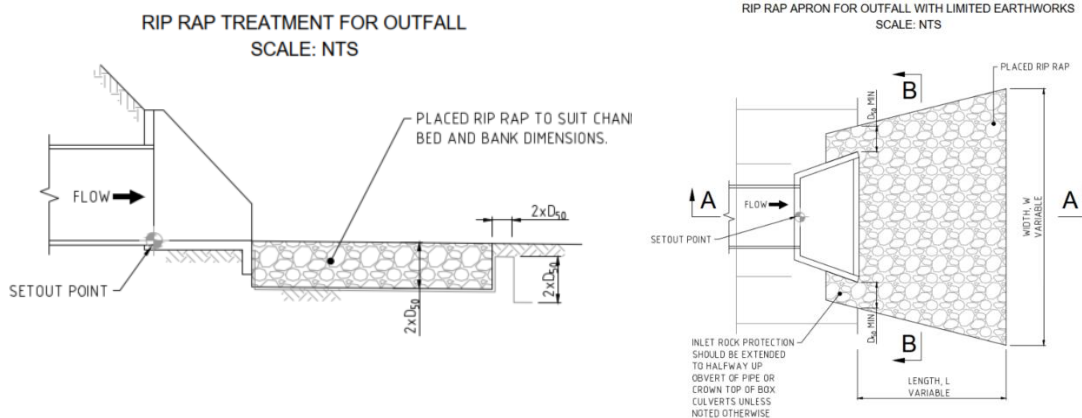

Plate 6.6 Headwall detail with scour protection for permanent works

Source: Mott MacDonald.

6.86.7 Field Drainage Management

6.8.16.7.1 Where the existing field drainage is affected by the temporary works and permanent works, the field drainage must be correctly managed with the agricultural owner or manager of the agricultural land affected by the scheme. As stated in Section 5.2, field drainage would be expected in the agricultural fields. The average depth of the field drains is assumed to be 0.9m as per Section 4.5 of this report, based on the Rural Sustainable Drainage Systems (RSuDS) by the EA that provides a list of existing land management options and guidance for farmers and land managers to install Rural sustainable drainage system.

Affected Field Drainage in Permanent Works

6.8.26.7.2 The permanent works include the normal features of a substation, converter station and external access roads.

- External access roads are expected to reach a depth between 0.5m and 0.7m depending on ground conditions. The risk of the roads affecting the existing land drainage is low, provided crossings are designed in to the access roads.
- Substations and converter stations sit on agricultural land. They are formed on top of existing ground on a raised flat platform. Diversion may be required where / if field drainage is affected by the substation and converter station footprint. However, it is anticipated that the risk of the platform affecting the existing land drainage is low.

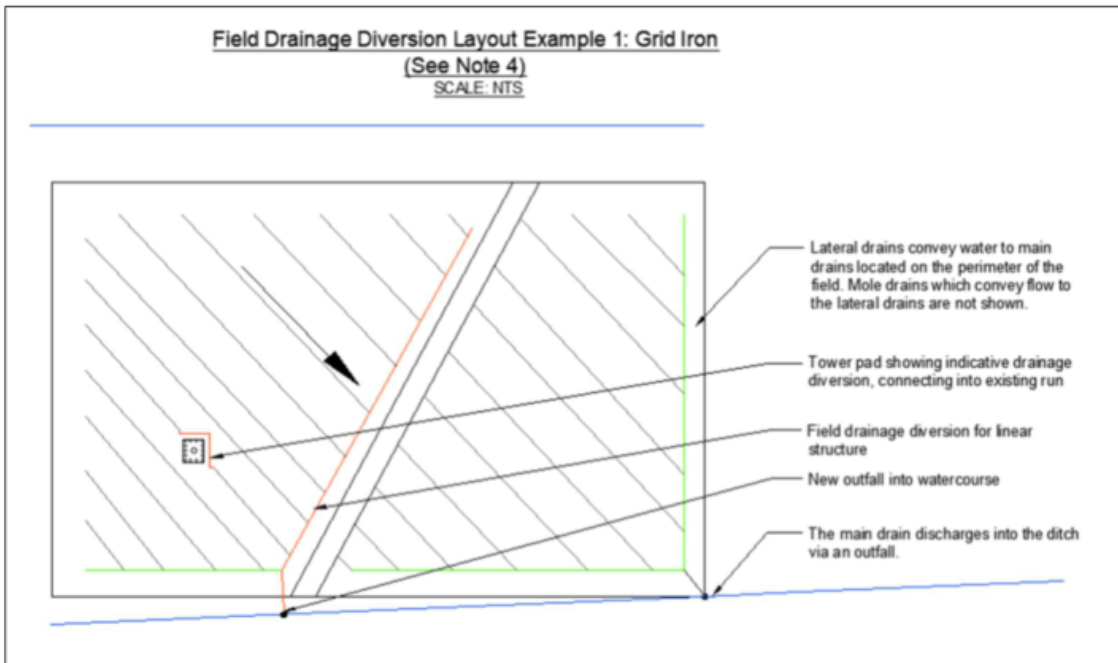

Plate 6.8 Field drainage diversion layout example

Source: Mott MacDonald.

New Field Drainage

[6.8.56.7.5](#) Where it is necessary to install new land drainage, the following guidance will be followed.

[6.8.66.7.6](#) Newly installed field drains should not drain working areas that have been stripped of topsoil. Where the drains may present a pollution risk, solid (not perforated) pipe should be used and in-line filters and sumps installed, as referenced in CIRIA 648 – “Control of Water Pollution from Linear Construction Projects”.

[6.8.76.7.7](#) CIRIA 648 notes that the main contractor can be held responsible for the quality of water diverted through the works and discharged from an outfall used during construction. The contractor must therefore be aware of any activities upstream (such as muck-spreading or plough) that may cause polluted water to enter the diverted land drains. In order to avoid polluted water entering into the land drains due to the works upstream the diversion, the contractor should install attenuation/sediment control basins on the line of the diversion, upstream of the receiving watercourse.

[6.8.86.7.8](#) Affected land drains should be sealed, upslope and downslope, where they cross the site and care taken to ensure that the land upslope will not become waterlogged or flood as a result.

[6.96.8](#) Groundwater Management Features

[6.9.16.8.1](#) Existing groundwater conditions are stated in the Section 5.4 of this report. If groundwater is encountered during the installation of the cable route, substations, and converter stations the proposed mitigations are described below.

Cable Trenches

6.9.26.8.2 The cables will typically be at a depth of approximately 1.1m and held within trenches approximately 1.5m deep and 1.5m wide. The cables will be installed in a UPVC duct, surrounded by cement bound sand wrapped in a geotextile, the trenches backfilled and the ground re-instated. Foundation depths have not been confirmed but are expected to be similar to the haul road with a depth between 0.2m and 0.7m depending on ground conditions, but it would vary as per ground conditions.

6.9.36.8.3 Depending on the porosity of the backfill and the geotextile, the trenches may act as a channel and convey water elsewhere. It is expected that this can be managed if the hydrogeology indicates its necessary through mitigations outlined in site specific hydrogeological risk assessments, such as the use of regularly spaced puddle clay stanks to prevent groundwater conveyance within the backfill. An alternative solution to avoid conveyance of the groundwater within the backfill is if the backfill is well-compacted to prevent voids that would convey groundwater.

6.9.46.8.4 All jointing bays along the cable route will be protected from groundwater. A reinforced concrete slab will support the joint units with drainage sumps either end and backfilled with sand or gravel during construction phase. The joint units are resilient to flooding and typically need access every 4-5 years for inspection. The jointing bays will follow the same drainage strategy as the underground cables. At cable joint bays, sumps are provided to soak any water that may fall into them or groundwater that could enter them during construction. Upon construction, joint bays are backfilled, so no standing water is assumed to remain within them. Thus, it is considered the cables have sufficient protection against flooding.

6.9.56.8.5 Subject to this mitigation, installation of the cables is not expected to increase flood risk or cause any localised raising of the groundwater levels.

Plate 6.9 Spaced puddle clay stanks along the cable route in the areas prone to groundwater risk

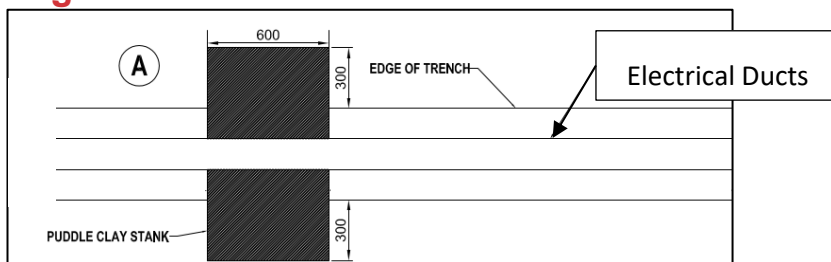

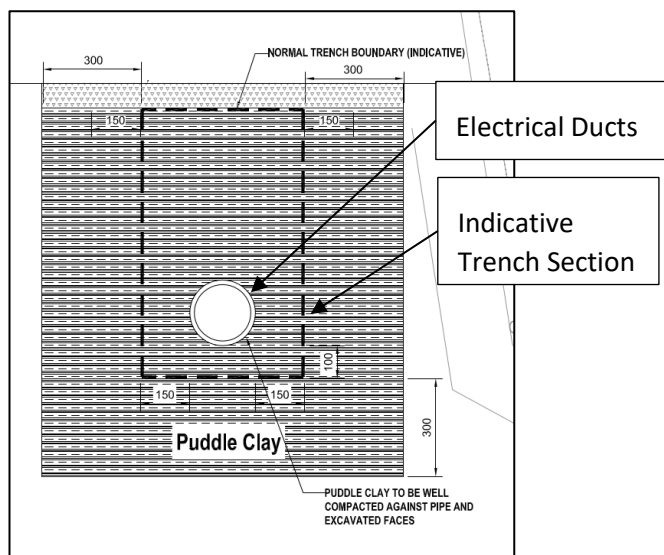

Plate 6.9 Spaced puddle clay stanks along the cable route in the areas prone to groundwater risk

Source: Mott MacDonald (2024)

Substation and Converter Station

[6.9.66.8.6](#) The proposed substation and converter stations platform sit on agricultural land. They are formed on top of existing ground on a raised flat platform. The proposed combined substation and converter station subbase level will be higher than the levels at which groundwater will be encountered. The proposed substation and converter stations platform is normally formed by an uplift of capping material above the existing ground, on top of the capping material a layer of permeable gravel will form the wearing course of the substation/converter station platform.

[6.9.76.8.7](#) The finish platform level of the substation and converter station is informed by the FRA.

Attenuation Basins

[6.9.86.8.8](#) The bases of all proposed attenuation basins are generally expected to be above groundwater levels. Where groundwater is elevated, lining of the basins with an impermeable [geotextile or natural](#) liner may be necessary to mitigate groundwater ingress, and anchoring of the liner may be required to manage buoyancy. The liner should be anchored to prevent uplift and the maximum basin depths will be limited to 0.5-1m deep and 0.3m freeboard.

[6.9.96.8.9](#) The maximum depth of the basins is restricted due to the uncertainty of the groundwater table. Proposed basin depth is 0.5m. An assessment of the groundwater and elevation of the site has been carried out to obtain the proposed basin depths. In areas where the topography is flat and there is proximity to a watercourse, the basin depth is limited to 0.5m to reduce the risk of groundwater flooding.

7. Foul Water Drainage

- 7.1.1 The strategy of the foul water drainage design is established for two scenarios:
- Temporary foul drainage for the construction compounds.
 - Permanent foul drainage for the permanent features (substation and converter station).

7.2 Temporary Foul Water

- 7.2.1 Construction compounds will include portacabins for the staff as part of the onsite welfare facilities. The proposed construction compound layout is included in **2.13 Design and Layout Plans [APP-037]**.
- 7.2.2 It is proposed that there will be an independently managed foul drainage system within the construction compounds to contain waste produced from welfare and toilet facilities. It is expected that the foul water will be contained on site and regularly pumped, emptied, and transported off site. Therefore, there is no requirement for any formal piped foul drainage on site or any offsite connection.

7.3 Permanent Foul Water

- 7.3.1 **2.13 Design and Layout Plans [APP-037]**.
- 7.3.2 Permanent foul water drainage is proposed for the operational use of the substations and converter stations. The proposed Converter Station and Substation Layout is included in **2.13 Design and Layout Plans [APP-037]**.
- 7.3.3 The converter station and substation contain a single storey service building with onsite welfare facilities for the staff. However, no internal layouts have been developed at the current stage of the design. Consequently, foul water drainage has not been shown on scheme drawings.
- 7.3.4 National Grid guidance for site drainage (TS 2.10.09) states that foul water shall connect into the public sewage system wherever possible.
- 7.3.5 There are public Southern Water sewers in the vicinity of the substation and converter site, and Weatherlees Hill Wastewater Treatment Works sits 500m to the southeast of the proposed substation and converter site. Therefore, it is possible that a new foul water connection may be installed, 1.5km in length, following the route of the new proposed access road to the new substation and converter station. This will need to be a pumped rising main due to its length. Alternatively a septic tank or treatment works shall be provided.
- 7.3.6 Southern Water will be consulted at a later design stage for the wastewater consent for the foul water connection of the new substation and converter station via Section 106 of the Water Industry Act if required.

8. Water Quality

- 8.1.1 This Drainage Strategy is required to demonstrate that the scheme will not cause unacceptable deterioration to water quality and improves the water quality via a sustainable drainage system.
- 8.1.2 The contractor usually applies for applicable licences after detailed design, in accordance with the projects [CEMP 7.5.3 Outline Onshore Construction Environmental Management Plan \[APP-340\]](#). Drainage Management Plans will be produced prior to commencement of development and approved by the relevant planning authority which will be produced substantially in accordance with the Drainage Strategies and are secured under Requirement 6 within the Development Consent Order. Drainage Management Plans must be substantially in accordance with the Drainage Strategies. The Drainage Management Plans will include a construction phase element and an operational phase element that may be discharged separately.
- 8.1.3 The temporary and permanent drainage systems on site will be designed to meet the water quality design criteria and good practice pollution control measures as outlined in the CIRIA SuDS Manual. Water quality management is to be finalised when construction compound layouts are confirmed as this will allow any high-risk areas to be identified and managed. The different areas of the site will be categorised by the appropriate pollution hazard level from Table 26.2 of The SuDS Manual.
- 8.1.4 At this stage proprietary treatment has not been shown on the drawings.

Water and Sediment Quality During Construction Phase

- 8.1.5 CIRIA C648 Control of water pollution from linear construction sites has been consulted. This document provides guidance for constructors and designers to minimise the water pollution before and during construction stage.
- 8.1.6 Surface water and groundwater are highly vulnerable to pollution and impact from construction activities. The proposed Kent cable route sits outside the catchment area of SPZs indicated in the Section 5.4 of this report.
- 8.1.7 The following construction activities require specific mitigations for water pollution:
- Uncontrolled sediment erosion and contaminated silty runoff.
 - Refuelling facilities and handling areas.
 - Polluted drainage from the site.
 - Works within water.
- 8.1.8 Mitigations are not limited to these activities, and it should be noted that the contractor is responsible for managing risk of water pollution from all activities during the construction phase.
- 8.1.9 The mitigation measures that will be taken to avoid water pollution:
- Use prefabricated concrete products for outfalls and bridge piers.
 - Bridges extended to locate piers inland rather than adjacent to a watercourse.

- Use stone gabions for bank reinforcement.
- Design shallow slopes in cutting /embankments to slow down the runoff, increase the infiltration and trap sediment.
- Establishing riparian buffers to protect watercourses and implement silt fences.
- Filtration (silt traps in the form of hay bales) units to intercept silt-laden water from the site to be discharged into the ditch.
- Sediment filter logs: A temporary sediment barrier of excelsior or coconut fibre used to intercept sediment runoff and help stabilize slopes. Protects storm drains, runoff ditches, brooks, streams, rivers, lakes and riparian banks.
- Using erosion control blankets in embankments to reduce concentrated flows, which also protects existing ditches and swales from new discharge flows.
- When directional drilling is the construction method selected for a watercourse crossing, special consideration should be given to the protection of ground water.
- Sealed manholes to be used in the design of construction drainage civils to reduce the risk of contaminated water spillage in the event that contaminated water enters the drainage system from the construction elements (construction compound or haul road) if the system becomes surcharged.
- When discharging water from a dewatering system (generally clean water from excavations), where there is likely to be potential for silt-~~or other contamination~~; water should be discharged to-in a settlement basin or similar before discharging into a watercourse.

8.1.10 Management plans will be set out for the contractor to manage environmental risks associated with the construction phase:

- **7.5.3 Outline Onshore Construction Environmental Management Plan [APP-340] (CEMP)**
- A Drainage Management Plan shall be prepared by the contractor which describes the approach to surface water and foul water drainage, and water supply during construction phase.
- A Flood Management Plan for the construction phase.
- Construction Method Statements for Protection of Onshore Water

8.1.11 Trenchless techniques used should have an appropriate method statement. This will be prepared post-consent and prior to the undertaking of the relevant works.

Discharging Water into a River

8.1.12 To avoid existing waterbodies becoming contaminated by suspended sediments, the velocity of flows at the outfall should be reduced using baffles, blocks in the outfall apron or an energy-dissipater. The same consideration should be taken when over-pumping water along a watercourse.

8.1.13 Penstock or similar valves will be installed to automatically close or isolate the outfall in the event of a pollution incident. A monitoring and valve chamber will include a monitoring system designed to detect the pollutants posing a risk. The level of concentration of these pollutants can be set to within the sites allowable discharge limits and when exceeded, automatically close off the drainage route. The operation of the

penstock or similar valve system will have a manual override in the case of a failure in the automation system and all aspects of the system will be subject to routine inspection in line with the manufacturers recommendations.



Plate 8.1 Outfalls with bank protection for discharge outfall and baffles on discharge hoses for temporary works

Source: CIRIA C648.

Water Quality in Construction Compounds

8.1.14 Several construction compounds are proposed along the cable route. Early planning for the storage of potentially polluting materials, for supply and disposal of water, and for controlling runoff will reduce the risks of water pollution on site. The following has been considered in the proposed development:

- Locating the compound away from watercourses (including ditches) and aquifers.
- Avoiding locations that are designated conservation areas.
- Identifying areas with permitted access by public main road (reducing the need for haul roads).
- Considering the above points as priority, then identifying locations that already have services in place (e.g., hardstanding, water supply, power and connection to foul drainage systems).

8.1.15 The construction compounds will require the following:

- Agreements obtained for wastewater disposal.
- Locations selected for cesspits or package plants where no foul connection is available.
- Suitable refuelling area(s) selected on hardstanding with drainage via oil interceptor. The plant refuelling areas will have a concrete bund and runoff will run through an oil separator before entering the dirty filter drains or swales.
- Provision of adequate measures to control runoff from compounds and haul roads.

- Provision of a suitable vehicle wash area on hardstanding which drains to foul or shall be suitably treated on site.

8.1.16 To minimise the pollution in the construction compounds the following mitigations have been considered:

- The construction compound surfacing will utilise permeable materials where appropriate. Consideration should be given to the prevention of clogging of the permeable pavement by sediments. Permeable paving is particularly effective at removing the main pollutants: suspended solids, hydrocarbons, and metals.
- An area for settlement of silts is to be included within the attenuation basins as the treatment method for sediment control. All settlement basins will be provided with oil absorbents to absorb any hydrocarbons accumulated.
- Runoff from adjacent ground will be intercepted and prevented from entering the site, as this creates additional polluted runoff.

8.1.17 Compounds are to implement water conservation measures where appropriate:

- Water from settlement basins can be pumped into a bowser and used to damp down haul roads and site compounds to prevent the generation of dust.
- Vehicle washing should only be used in a bunded area where the runoff can be contained and channelled to a treatment area, such as a settlement basin, prior to discharge. Runoff from washes and vehicle wash bays must not be allowed to enter surface water or foul water drainage systems without permission.
- Storage areas should sit away from sensitive receptors, at least 10m from a watercourse or a land drain.

Water Quality in Haul Roads and Site Access

8.1.18 To minimise pollution from the haul roads the following mitigations are proposed:

8.1.19 Haul road stabilisation reduces on-site erosion, reducing the sediment that may pollute nearby streams or be transported off site. There is potential for geogrid layers or other type of soil additives to be used for stabilisation. To minimise environmental impact, the following should be considered:

- Control of run off: After addition of binders – ensure fully mixed, fully compacted and curing protection applied.
- Dust control to avoid contamination of nearby watercourses.
- Haul road surfacing could be constructed using permeable materials where no groundwater is encountered, but consideration should be given to clogging of the permeable pavement by sediments which is very likely on a construction site. Permeable paving is particularly effective at removing the main pollutants: suspended solids, hydrocarbons and metals.
- Ditches/swales should be constructed on either side, or on the downslope side, of haul roads to channel water to a treatment area (settlement basin).
- Check dams and sediment traps across swales or drainage ditches to reduce the runoff velocity and promote the sedimentation. Swales can remove hydrocarbons.
- Haul road crossing a stream: Straw bales should be positioned at either end of the culvert to prevent suspended solids moving along the watercourse.

- Where an existing bridge structure is used for a haul road, mud and debris should not be allowed to build up. Straw bales or sandbags should be placed along the edge of the existing bridge to prevent silty water running off into the water below.

Water Quality During Operational Phase

- 8.1.20 The proposed surface water drainage system will improve the water quality of surface water runoff from the scheme, which ultimately outfalls to existing watercourses. This will be done by using a treatment chain where each subsequent system within the proposed drainage network provides treatment to improve water quality.
- 8.1.21 The proposed surface water treatment method will depend on the potential hazards on the site and the sensitivity of the receiving water body to pollution.
- 8.1.22 All transformer bunds will drain into oil water separator tanks that discharge into the platforms underground drainage system. In line with National Grid Standard TS 2.10.01, all transformers will have a totally sealed bund with a sump, which has a bund water control unit to pump any water out. This will be directed through an oil separator to pick up any potential small levels of residual oil before being discharged into the main operational platform drainage system.
- 8.1.23 Access roads will drain into a filter drain system or the permeable platform, which will provide an adequate level of water quality treatment.

8.2 Consents

- 8.2.1 Licenses and consents required from drainage stakeholders in addition to the DCO should be applied for and granted before construction activities start. Early engagement with drainage stakeholders is discussed in Appendix D.
- 8.2.2 These consents establish the requirements for the following activities:
- discharging sewage to a foul sewer
 - discharging water to surface water (waterbody or sewer) or groundwater
 - pumping water from surface water or groundwater
 - working in or near water
 - working in tidal waters

Discharging Water to Foul Water

- 8.2.3 To discharge to a public foul sewer, permission from the statutory sewerage undertaker is required, which depending on the contents may require a trade effluent consent.

Discharging Water to Surface Water (Waterbody or Sewer) or Groundwater

- 8.2.4 The discharge of any matter to surface or groundwater requires a written “discharge consent” issued under the Water Resources Act 1991 by the EA, LLFA or the sewerage undertaker. If water is being abstracted prior to discharge (e.g., from an excavation or through dewatering to lower the water table), a transfer licence may be required. These

consents include agreement of the type of treatment prior to discharge, volume and rate of discharge, nature of the discharge (from groundwater or surface water).

8.2.5 All new surface water discharges into an ordinary watercourse within the Internal Drainage District, which are the result of development, must be consented by the Board under our Byelaw 3.

8.2.6 The Kent County Council (KCC) has powers under Section 23 of the Land Drainage Act 1991 to consent works in an ordinary watercourse (when crossing a watercourse within the IDB district).

Abstracting and Dewatering

8.2.7 For dewatering or pumping out of water that has collected in an excavation or shaft, an abstraction licence is not required. However, a discharge consent may be required from the EA to dispose of or transfer the dewatered water.

8.2.8 Before any dewatering to lower the water table takes place, the environmental regulator must be consulted so it can issue appropriate authorisation.

Working in or Near Water (including outfall and bank-side structures)

8.2.9 ~~The Land Drainage Act 1991 requires that a~~ consent is applied for and granted by the relevant water authority/[regulator](#) for the following activities:

- works in, over or under any main river,
- works in, over or under all other watercourses (ordinary watercourses) if the flow is likely to be affected,
- temporary works affecting the channel of main rivers or ordinary watercourses,
- temporary and permanent works in the floodplain of main rivers.

8.2.10 Works within 7–10 m from the top of a main river or IDB watercourse bank may also require consent. Consultation should be undertaken with the EA/IDB to determine whether consent is needed. “Works” include temporary works such as a haul road, culvert diversion or stream diversion, as well as permanent works such as a new road bridge.

8.2.11 There should be no storage of spoil directly on watercourse banks. Where possible, spoil will be set back from watercourses by 10m. For main rivers, this is increased to 15m as secured by mitigation W02 of **7.5.3.2 CEMP Appendix B Register of Environmental Actions and Commitments (REAC) [APP-342]**. This will prevent excessive loading on the watercourse banks and minimise the risk of stored material entering the watercourses.

Working in Tidal Water

8.2.12 All works in the floodplain should be completed in the shortest possible timeframe.

8.2.13 Construction licences are required for the placement of materials in the tidal zone below mean high water springs (MHWS), which includes the tidal waters of any estuary, creek, bay or river, under the Food and Environment Protection Act 1985 (FEPA).

8.2.14 Permission must be obtained from the environmental regulator to ensure that the design and operation of the development in the floodplain is not likely to increase the potential for flooding or create a risk of flood damage. Mitigation W12 within **7.5.3.2 CEMP**

Appendix B Register of Environmental Actions and Commitments (REAC) [APP-342] sets out how this will be demonstrated.

9. Amenity

- 9.1.1 Standard 5 of the national standards for SuDS states that “A SuDS approach shall be adopted that maximises benefits for amenity through the creation of multi-functional places and landscapes”
- 9.1.2 To achieve this, the design of SuDS components seek to enhance the provision of high quality, attractive public space which can help provide health and wellbeing benefits, improve liveability for local communities and contribute to improving the climate resilience of new developments.
- 9.1.3 The guidance within Standard 5 explains how SuDS can add amenity value by contributing towards:
- making a multifunctional space, positively contributing to placemaking and environmental enhancement;
 - taking influence from the landscape character to ensure public acceptability and maximising amenity benefits;
 - reducing hazards from climate change;
 - promoting the safety and well-being of site users; and
 - educating the public on the benefits and function of proposed SuDS components
- 9.1.4 The drainage design seeks to make multifunctional use of the civil drainage infrastructure, by making many of the attenuation open-air in the form of basins, which add environmental enhancements to the scheme. It should be noted that the sites of the scheme are not inherently public amenity spaces.
- 9.1.5 Whilst the sites of the scheme are not public amenity space, the drainage design is intended to reflect the landscape character, by avoiding unnecessary earthworks and infrastructure wherever necessary.
- 9.1.6 As the drainage design accommodates a climate change uplift to rainfall, it inherently seeks to reduce the hazards of climate change.
- 9.1.7 Adjacent to access roads, filter drains are proposed wherever possible to facilitate a safe working environment, as open ditches would increase the risks to construction traffic.

10. Biodiversity

- 10.1.1 Standard 6 of the National Standards for SuDS states that “A SuDS approach shall be adopted to ensure the surface water drainage system maximises biodiversity benefits throughout the development lifecycle”
- 10.1.2 The proposed surface water drainage design shall add biodiversity value by:
- Creating diverse, self-sustaining, resilient local ecosystems which contribute to net gains in biodiversity
 - Supporting and promoting natural local habitat and species
 - Contributing to the delivery of local biodiversity strategies
 - Contributing to habitat connectivity
- 10.1.3 **6.2.3.2 Part 3 Kent Chapter 2 Ecology and Biodiversity [AS-047]** as part of the Environmental Statement (ES) identifies scale and ecological sensitivity of the site and potential areas of habitat loss. Proposed SuDS for the development assist in mitigating biodiversity impacts of the development and support improvements to biodiversity.
- 10.1.4 While the ES states that there are habitat losses due to the development, these are not permanent losses. This is because there would be extensive habitat creation as part of the proposed project, around the Minster Converter Station and Substation, along the permanent access road, for landscape design and to facilitate drainage, and along the River Stour.
- 10.1.5 As a result, there would be a long-term increase in woody and wetland habitats due to the Kent Onshore Scheme, increasing the ecological value of what is currently a predominantly arable landscape of relatively low diversity of habitat structure.
- 10.1.6 An example of habitat creation as stated in the ES is the attenuation basins around the Minster Converter Station and Substation, resulting in an increase in wetland perimeter habitat of around 1.38km. Refer to the ES for more detail on the potential benefits and impacts on ecology and biodiversity of the Kent Onshore Scheme.

11. Design of Drainage for Construction, Operation, Maintenance, decommissioning and Structural Integrity

11.1.1 Standard 7 of the National SuDS Standards requires that:

- All elements of the surface water drainage system should be designed so that they can be constructed easily, safely, cost-effectively, in a timely manner, and minimising negative impacts on the environment;
- All elements of the surface water drainage system should be designed so that maintenance and operation can be undertaken easily, safely, cost-effectively, in a timely manner, and minimising embedded carbon; and
- The surface water drainage system should be designed to ensure structural integrity of all elements over the design life.
- The surface water drainage system will be designed and detailed in accordance with current best practice and guidance to meet this standard.

11.2 Maintenance

11.2.1 It is likely that operator will be responsible for maintaining the SuDS within the development. Section 32.4 of the SuDS Manual categorises maintenance work as follows:

- Regular maintenance – includes basic tasks which should be carried out to a frequent and predictable schedule.
- Occasional maintenance – includes tasks that are likely to be required on a regular basis but at a less frequent rate compared to regular maintenance.
- Remedial maintenance – includes tasks that may be required to rectify faults associated with the system. Although the amount of remedial maintenance can be reduced via good design and construction, unforeseen issues can occur. Remedial maintenance may be required due to site specific characteristic or unforeseen events.

11.2.2 As part of the design of the SuDS, a SuDS Asset Maintenance Plan will need to be developed that sets out the regime for their maintenance and a schedule for each of the maintenance tasks. An example of maintenance for the proposed SuDS is seen in Table 11.1 below.

Table 11.18 SuDS maintenance plan description

SuDS Type	Maintenance Type	Description
Attenuation Basin	Routine/ Regular Maintenance	Remove litter and debris Cut grass Inspect inlets, outlets and overflow blockages and clear if required Check any penstocks and other mechanical devices
	Occasional Maintenance	Remove sediment when required
	Remedial Maintenance	Repair/rehabilitate inlets, outlets and overflows
Filter Drains	Routine/ Regular Maintenance	Mow grassed edge surrounding the drain monthly or as required.
	Occasional Maintenance	Hand pull weed growth in filter drain as required, ensuring no weed killer enters the filter drain.
	Remedial Maintenance	When there is silt at the surface of the filter drain, remove and replace the surface stone layer. Additionally, replace and remove the perforated HDPE pipe as required.
Swales	Routine/ Regular Maintenance	Mow swale grass to 100mm with 150mm max to filter and control runoff, remove cutoffs to wildlife piles on site monthly or as required. Where wetland develops in the swale due to wet conditions, cut annually or as required.
	Occasional Maintenance	When there is a build-up of silts above the swale design level, remove and spread on site as required.
	Remedial Maintenance	Any damage to swales to be repaired to design profile as required.

11.3 Decommissioning

11.3.1 Permanent scheme drainage assets such as land drainage diversions and surface water networks shall be decommissioned or replaced at the end of their design life.

- 11.3.2 Haul roads constructed to deliver the scheme are temporary assets and will therefore be removed at the end of the construction period. This will include the removal of relevant cross drains and filter drains.
- 11.3.3 Attenuation basins are also temporary assets where they serve only the construction compounds and temporary haul roads. These are to be removed following completion of works, and the land reinstated to its previous use.

11.4 Structural Integrity

- 11.4.1 All materials and components used within the surface water drainage system shall be suitable to resist all imposed design loadings with appropriate factors of safety and shall have equivalent design life to the proposed development or have a replacement plan accounted for in the maintenance plan.
- 11.4.2 A separation distance of 1.2m is specified between the crown of the pipes to the FFL to protect piping below, as per the Sewerage Sector Guidance – Appendix C - Design and Construction Guidance¹⁷. If this separation distance cannot be achieved, concrete surrounds of pipes shall be proposed.
- 11.4.3 When proposed infiltration systems are within 5m of any existing or proposed buildings roads embankments or other infrastructure, risk shall be assessed and measures applied if required. Infiltration systems in ground which may be unstable may need to be an additional 5m away from the existing or proposed infrastructure.

¹⁷ [Sewerage Sector Guidance - approved documents | Water UK](#)

12. Conclusions and Recommendations

12.1 Assumptions and Risks

12.1.1 Appendix A includes assumptions, risks and opportunities for each contributing catchment area and basin.

12.1.2 In the absence of detailed information, some assumptions have been considered to produce this drainage strategy for the proposed Kent Sea Link cable route. The main assumptions are discussed below:

- The proposed discharge rate for all proposed attenuation and hybrid system has been restricted based on the estimated 'greenfield' run-off rate (Qbar) for the undeveloped site, A minimum advisable of 2l/s has been applied where Qbar is calculated to be <2l/s as per guidance from HR Wallingford Greenfield runoff rate estimation tool.
- Where proposed outfalls are located in proximity to one another, the consenting body may require outfalls to be combined. This could cause increase in size of attenuation basins, or re-location.
 - Contributing catchment areas have been calculated based the following assumptions with regards to % impermeable of the surfaces:
 - Haul Roads: 100% impermeable within their gross site areas
 - Permanent Access Roads: 100% impermeable within their gross site areas
 - Construction compounds: 70% impermeable within their gross site areas
 - HVDC construction swathe: 25% impermeable within their gross site areas
 - Substation and converter station: 50% impermeable within their gross site areas
- All outfalls identified during the production of this report are based on the latest topographical survey carried out by 3D engineering in November 2023. When topographical survey is not available, LIDAR or OSTerrain5 is used to identify the minimum elevation of the outfalls.
- The proposed locations for the attenuation basins are based on existing ground level and a gravity system (i.e. following the fall of the land) towards the watercourse where the attenuation basins discharge. The watercourse topography will dictate the outfall elevation and consequently, the location of the proposed basins. Where no data on the watercourse is available, recommendations for surveying the watercourses and then defining the elevation of the outfall are included in Appendix A for each contributing catchment area and basin.
- The proposed attenuation volumes do not include attenuation within the filter drains or swales. Consequently, the attenuation volumes of the basins will be refined at later design stages and there may be opportunity to reduce these volumes by utilising attenuation volume available in the upstream drainage features.
- It is proposed that a new ditch runs along the perimeter of the proposed platforms and construction swathe to absorb overland flows. It is assumed there will be a

suitable discharge connection into the closest watercourse from these land drains. If no suitable route can be identified to discharge by gravity into a watercourse, pumping could be required and possibly attenuation.

- The development design accounts for fully saturated ground, and the need to dewater groundwater for the installation of any infrastructure required to be built in dry conditions.

12.2 Opportunities

12.2.1 All attenuation basins should have a minimum clearance from overhead columns as defined by the Overhead Electrical Engineer. At the current stage of the project the specific clearance requirements for each existing column has not been defined. Each column could have a different clearance, and this will be stated in a subsequent stage of the project. The current design conservatively assumes all basins to have a clearance of 15m from any existing column, providing the biggest land take. There will be an opportunity to relocate the basins when the clearance for each overhead column is defined at later stage.

Appendix A Preliminary Drainage Design Summary

1 Appendix A: Draft Preliminary Drainage Design Summary

- Storage volumes within upstream pipework, filter drains, etc, have been excluded from pond storage calculations.
- Volumetric Runoff Coefficient, Cv values for summer and winter set to 1.
- Where a proposed attenuation pond is used for temporary sediment control during construction, a settling pond or vegetated forebay within the main pond should be included to trap sediments. Sediment trap should be approximately 20% of the pool volume. This extra volume is being excluded from the attenuation volume calculations.
- The Lower/Higher factor of confidence is defined based on the background information available at the time of drafting this report. Where any design value is assumed, a Low Confidence is given to the design.
- All outfall levels are revised as per new topographical survey data. (Topographical survey by 3D Engineering Surveys Limited dated October 2023).
- The method to produce the drainage calculations has used the following input data:
 - The proposed catchment areas have been extracted from the scheme plans and assigned the appropriate design criteria (for temporary and permanent design).
 - The discharge rates have been associated to each catchment area according to the impermeable area of each catchment following the criteria for the post-development discharge rate Qbar.
- Catchment descriptors have been imported from the UK Centre for Ecology and Hydrology (CEH) Flood Estimation Handbook (FEH) for three catchments, see Appendix C. This FEH data has been used to obtain the greenfield runoff rates in accordance with KCC Local SUDS Guidance. FEH Catchment descriptors used are listed below:
 - FEH Catchment Descriptors: 631000_163000 (Main Catchment)
 - FEH Catchment Descriptors: 633650_162400 (East Catchment)
 - FEH Catchment Descriptors: 631200_162650 (South Catchment)
- Point descriptors for runoff rate estimation have been imported from the UK Centre for Ecology and Hydrology (CEH) Flood Estimation Handbook (FEH) in three locations to provide representative rainfall prediction throughout the scheme, see Appendix C. FEH data is used to estimate the rainfall depths and volumes in accordance with the requirements of National Grid guidance TS 2.10.09 and KCC Local SUDS Guidance. FEH point rainfall used for the rainfall is listed below:
 - FEH point rainfall: 630997_163011 (Main Catchment)

- FEH point rainfall: 633384_162747 (East Catchment)
- FEH point rainfall: 631199_162651 (South Catchment)
- Pond Reference name:
 - TC: Temporary Catchment
 - PC: Permanent Catchment
 - ATPN: Attenuation Pond

POND REFERENCE	CONTRIBUTING CATCHMENT AREA (HA)	MINIMUM ATTENUATION VOLUME (M3)	OUTFALL DETAILS					
			DISCHARGE RATE (L/S)	DEPTH OF POND (M)	OWNER	CONSENTING BODY	CONFIDENCE	NOTES
Temporary TC-01-ATPN	2.12ha (HDD Construction Compound, its haul road)	2105.10	2.68	1	Private	IDB	High	Notes: SSL carried out ground investigation (BH8 and TP201) in close proximity to the proposed pond. BH8 Summary: Groundwater seepage at 1.10m depth. Includes groundwater monitoring. TP201 Summary: Trial pit remained dry and stable during excavation. No water strike observed. FEH catchment descriptor 633650_162400 is used for this area. FEH point rainfall 633384_162747 is used for this area. There is topographical survey data for the top of the embankment ditch and bottom of the ditch: top of the ditch is +2mAOD and bottom of the ditch is +1m AOD. Outfall Data: IL=+0.5mAOD.
Temporary TC-02-ATPN	0.17ha (haul road)	71.90	2	0.5	Private	IDB	High	Notes: SSL carried out ground investigation (TP501) in close proximity to the proposed pond. TP501 Summary: Water seepage at 3.50m depth. FEH catchment descriptor 633650_162400 is used for this area. FEH point rainfall 633384_162747 is used for this area. There is topographical survey data for the top of the embankment ditch and bottom of the ditch: top of the ditch is +2mAOD and bottom of the ditch is +1m AOD. Outfall Data: IL=+0.5mAOD.
TC-05-ATPN (Temporary Case)	10.09ha (HDD laydown area, laydown area)	5179.20	9.74	0.5	Private	IDB	High	Notes: SSL carried out ground investigation (TP204) in close proximity to the proposed pond. TP204 Summary:

POND REFERENCE	CONTRIBUTING CATCHMENT AREA (HA)	MINIMUM ATTENUATION VOLUME (M3)	OUTFALL DETAILS					
			DISCHARGE RATE (L/S)	DEPTH OF POND (M)	OWNER	CONSENTING BODY	CONFIDENCE	NOTES
	and HVDC cable swathe)							Water seepage at 1.20m depth.. FEH catchment descriptor 631000_163000 is used for this area. FEH point rainfall 630997_163011 is used for this area. There is topographical survey data for the top of the embankment ditch and bottom of the ditch: top of the ditch is +1.7mAOD and bottom of the ditch is +0.18m AOD. Outfall Data: IL=+1.2mAOD. Temporary pond to be reduced for the permanent case. Please see permanent pond PC-05-ATPN.
PC-05-ATPN (Permanent Case)	0.56ha (permanent access road and bellmouth access. The haul road within the HVDC cable swathe becomes the permanent access road to the converter station in the operational phase)	859.10	2	0.48	Private	SCC	Lower	Notes: Please refer to the Ground Investigation (GI) information used for the TC-05-ATPN. FEH catchment descriptor 631000_163000 is used for this area. FEH point rainfall 630997_163011 is used for this area. Temporary pond TC-5-ATPN to be reduced for the permanent phase to provide the volume required for PC-05-ATPN. Temporary pipe for TC-05-ATPN to be used for the permanent case with a reduced flow rate of 2l/sec.
TC-06-ATPN (Temporary Case)	0.99ha (HVDC cable swathe)	121.30	2	0.5	Private	IDB	High	Notes: SSL carried out ground investigation (TP503, 503A and BH501) in close proximity to the proposed pond. TP503 Summary: Trial pit terminated at 0.92m depth due to the presence of a bone, location moved and renamed TP503A. TP503A Summary: Water seepage at 1.50m depth.

POND REFERENCE	CONTRIBUTING CATCHMENT AREA (HA)	MINIMUM ATTENUATION VOLUME (M3)	OUTFALL DETAILS					
			DISCHARGE RATE (L/S)	DEPTH OF POND (M)	OWNER	CONSENTING BODY	CONFIDENCE	NOTES
								BH501 Summary: Groundwater seepage at 1.00m depth. There is topographical survey data for the top of the embankment ditch and bottom of the ditch: top of the ditch is +1.62mAOD and bottom of the ditch is +0.12m AOD. Outfall Data: IL=+1.2mAOD. FEH catchment descriptor 631000_163000 is used for this area. FEH point rainfall 630997_163011 is used for this area. Temporary pond to be reduced for the permanent case. Please see permanent pond PC-06-ATPN.
PC-06-ATPN (Permanent Case)	0.15ha (permanent access road and bellmouth access. The haul road within the HVDC cable swathe becomes the permanent access road to the converter station in the operational phase)	135.50	2	0.5	Private	IDB	High	Notes: Please refer to the Ground Investigation (GI) information used for the TC-06-ATPN. FEH catchment descriptor 631000_163000 is used for this area. FEH point rainfall 630997_163011 is used for this area. Temporary pond TC-06-ATPN to be increased in size for the permanent phase to provide the volume required for PC-06-ATPN. Temporary pipe for TC-06-ATPN to be used for the permanent case. FEH catchment descriptor 631000_163000 is used for this area. FEH point rainfall 630997_163011 is used for this area.
TC-07-ATPN (Temporary Case)	0.54ha (haul road)	96.30	2	0.5	Private	IDB	High	Notes: SSL carried out ground investigation (TP503, 503A and BH501) in close proximity to the proposed pond. TP503 Summary: Trial pit remained dry and stable during excavation. Trial pit terminated at 0.92m depth due to the presence of a bone, location moved and renamed TP503A.

POND REFERENCE	CONTRIBUTING CATCHMENT AREA (HA)	MINIMUM ATTENUATION VOLUME (M3)	OUTFALL DETAILS					
			DISCHARGE RATE (L/S)	DEPTH OF POND (M)	OWNER	CONSENTING BODY	CONFIDENCE	NOTES
								<p>TP503A Summary: Water seepage at 1.50m depth.</p> <p>BH501 Summary: Groundwater seepage at 1.00m depth. It includes groundwater monitoring.</p> <p>There is topographical survey data for the top of the embankment ditch and bottom of the ditch: top of the ditch is +1.3mAOD and bottom of the ditch is -0.27m AOD.</p> <p>Outfall Data: IL=+0.9mAOD.</p> <p>FEH catchment descriptor 631000_163000 is used for this area.</p> <p>FEH point rainfall 630997_163011 is used for this area.</p> <p>Temporary pond to be reduced for the permanent case. Please see permanent pond PC-07-ATPN.</p>
PC-07-ATPN (Permanent Case)	0.07ha (permanent access road. The haul road within the HVDC cable swathe becomes the permanent access road to the converter station in the operational phase)	38.40	2	0.5	Private	IDB	High	<p>Notes: Please refer to the Ground Investigation (GI) information used for the TC-07-ATPN.</p> <p>Temporary pond TC-07-ATPN to be reduced for the permanent phase to provide the volume required for PC-07-ATPN.</p> <p>Temporary pipe for TC-07-ATPN to be used for the permanent case.</p> <p>FEH catchment descriptor 631000_163000 is used for this area.</p> <p>FEH point rainfall 630997_163011 is used for this area.</p>
TC-08-ATPN (Temporary Case)	0.39ha (haul road)	34	2	0.5	Private	IDB	High	<p>Notes: SSL carried out ground investigation (TP503, 503A and BH501) in close proximity to the proposed pond.</p> <p>TP503 Summary: Trial pit remained dry and stable during excavation.</p>

POND REFERENCE	CONTRIBUTING CATCHMENT AREA (HA)	MINIMUM ATTENUATION VOLUME (M3)	OUTFALL DETAILS					
			DISCHARGE RATE (L/S)	DEPTH OF POND (M)	OWNER	CONSENTING BODY	CONFIDENCE	NOTES
								Trial pit terminated at 0.92m depth due to the presence of a bone, location moved and renamed TP503A. TP503A Summary: Water seepage at 1.50m depth. Trial pit remained stable during excavation. BH501 Summary: Groundwater seepage at 1.00m depth. There is topographical survey data for the top of the embankment ditch and bottom of the ditch: top of the ditch is +1.3mAOD and bottom of the ditch is -0.27m AOD. Outfall Data: IL=+0.9mAOD. FEH catchment descriptor 631000_163000 is used for this area. FEH point rainfall 630997_163011 is used for this area. Temporary pond to be reduced for the permanent case. Please see permanent pond PC-08-ATPN.
PC-08-ATPN (Permanent Case)	0.08ha (permanent access road. The haul road within the HVDC cable swathe becomes the permanent access road to the converter station in the operational phase)	48	2	0.5	Private	IDB	High	Notes: Please refer to the Ground Investigation (GI) information used for the TC-08-ATPN. Temporary pond TC-08-ATPN to be increased in size for the permanent phase to provide the volume required for PC-08-ATPN. Temporary pipe for TC-08-ATPN to be used for the permanent case. FEH catchment descriptor 631000_163000 is used for this area. FEH point rainfall 630997_163011 is used for this area.
Permanent PC-09-ATPN	3.61ha (western converter)	4066.70	4.07	0.5	Private	IDB	High	Assumptions: SSL carried out ground investigation (TP205, CP109 and CP111) in close proximity to the proposed pond.

POND REFERENCE	CONTRIBUTING CATCHMENT AREA (HA)	MINIMUM ATTENUATION VOLUME (M3)	OUTFALL DETAILS					
			DISCHARGE RATE (L/S)	DEPTH OF POND (M)	OWNER	CONSENTING BODY	CONFIDENCE	NOTES
	station catchment)							TP205 Summary: Trial pit remained dry and stable during excavation. No water strike observed. CP109 Summary: Trial pit remained dry and stable during excavation. CP111 Summary: Trial pit remained stable during excavation. Water seepage at 0.85m depth. There is topographical survey data for the top of the embankment ditch and bottom of the ditch: top of the ditch is +2.1mAOD and bottom of the ditch is -0.31m AOD. Outfall Data: IL=+1.2mAOD. FEH catchment descriptor 631000_163000 is used for this area. FEH point rainfall 630997_163011 is used for this area.
Permanent PC-10-ATPN	2.31ha (substation platform)	2482.20	2.78	0.5	Private	IDB	High	Notes: SSL carried out ground investigation (BH103, TP106 and CP103 and CP108) in close proximity to the proposed pond. BH103 Summary: Groundwater seepage at 0.85m depth. TP106 Summary: Trial pit remained dry and stable during excavation. Water strike not observed. There is topographical survey data for the top of the embankment ditch and bottom of the ditch: top of the ditch is +2.1mAOD and bottom of the ditch is -0.31m AOD. Outfall Data: IL=+1.2mAOD. FEH catchment descriptor 631000_163000 is used for this area. FEH point rainfall 630997_163011 is used for this area.
Permanent PC-11-ATPN	2.79	3566.0	3.21	0.5	Private	IDB	High	Notes:

POND REFERENCE	CONTRIBUTING CATCHMENT AREA (HA)	MINIMUM ATTENUATION VOLUME (M3)	OUTFALL DETAILS					
			DISCHARGE RATE (L/S)	DEPTH OF POND (M)	OWNER	CONSENTING BODY	CONFIDENCE	NOTES
	(eastern converter station catchment)							SSL carried out ground investigation (BH102, TP101, TP102, CP101 and CP102) in close proximity to the proposed pond. BH102 Summary: Groundwater strike at 8.30m depth, rising to 6.40m depth after 20 minutes Groundwater strike at 8.30m depth, rising to 6.40m depth after 20 minutes. TP101 Summary: No water strike observed. Trial pit depth 3.6m. TP102 Summary: Water seepage at 1.50m depth. Trial pit remained stable during excavation. CP101 Summary: Water seepage at 1.10m depth. There is topographical survey data for the top of the embankment ditch and bottom of the ditch: top of the ditch is +2.1mAOD and bottom of the ditch is -0.31m AOD. Outfall Data: IL=+1.2mAOD FEH catchment descriptor 631000_163000 is used for this area. FEH point rainfall 630997_163011 is used for this area.
Temporary TC-11-ATPN	4.44ha (laydown area)	2860.20m3 required volume. Two ponds with combined volume 1480m3 and 1380.20m3 subbase storage.	4.82	0.5	Private	IDB	High	Notes: SSL carried out ground investigation (TP504) in close proximity to the proposed pond. TP504 Summary: Trial pit remained dry and stable during excavation. There is topographical survey data for the top of the embankment ditch and bottom of the ditch: top of the ditch is +2.1mAOD and bottom of the ditch is -0.31m AOD. Outfall Data: IL=+1.2mAOD FEH catchment descriptor 631000_163000 is used for this area.

POND REFERENCE	CONTRIBUTING CATCHMENT AREA (HA)	MINIMUM ATTENUATION VOLUME (M3)	OUTFALL DETAILS					
			DISCHARGE RATE (L/S)	DEPTH OF POND (M)	OWNER	CONSENTING BODY	CONFIDENCE	NOTES
								<p>FEH point rainfall 630997_163011 is used for this area.</p> <p>The 300mm thickness of Type 3 subbase of the laydown area provides an extra attenuation. The attenuation of the permeable subbase is based on the 30% porosity of the granular material.</p> <p>The attenuation proposed for the laydown area is a combination of two ponds with combined volume of 1480m³ and a minimum of 1380.20m³ subbase storage within the Type 3 permeable granular material of the laydown area.</p> <p>Opportunity: The proposed laydown area is 4.44ha and is formed by a 300mm Type 3 subbase. There is an opportunity to use the total thickness of the subbase to provide the attenuation volume required to discharge the reduced 4.82 l/sec.</p> <p>Attenuation volume of the subbase = thickness of the subbase * 0.3 porosity * area of the laydown = 0.3m x 0.3 x 40000 = 3600m³ of attenuation volume available within the Type 3 subbase of the laydown area.</p>
Temporary TC-12-ATPN	0.21ha (haul road)	95.60	2	0.5	Private	IDB	High	<p>Notes: There are no known ground investigation records by SSL. There is topographical survey data for the top of the embankment ditch and bottom of the ditch: top of the ditch is +2.1mAOD and bottom of the ditch is -0.31m AOD. Outfall Data: IL=+1.2mAOD FEH catchment descriptor 631000_163000 is used for this area. FEH point rainfall 630997_163011 is used for this area.</p>
Temporary TC-13-ATPN	0.33ha (haul road)	186.30	2	0.42	Private	IDB	High	<p>Notes: There are no known ground investigation records by SSL. There is topographical survey data for the top of the embankment ditch and bottom of the ditch: top of the ditch is +2.1mAOD and bottom of the ditch is -0.31m AOD. Outfall Data: IL=+1.2mAOD</p>

POND REFERENCE	CONTRIBUTING CATCHMENT AREA (HA)	MINIMUM ATTENUATION VOLUME (M3)	OUTFALL DETAILS					
			DISCHARGE RATE (L/S)	DEPTH OF POND (M)	OWNER	CONSENTING BODY	CONFIDENCE	NOTES
								FEH catchment descriptor 631000_163000 is used for this area. FEH point rainfall 630997_163011 is used for this area.
TC-14-ATPN Temporary	0.13 (haul road)	49	2	0.5	Private	IDB	High	Assumptions: SSL carried out ground investigation (TP506) near the proposed pond. TP506 Summary: Water seepage at 1.30m depth. Trial pit was unstable at 3.60m depth. There is topographical survey data for the top of the embankment ditch and bottom of the ditch: top of the ditch is +2.1mAOD and bottom of the ditch is -0.31m AOD. Outfall Data: IL=+1.2mAOD FEH catchment descriptor 631000_163000 is used for this area. FEH point rainfall 630997_163011 is used for this area.
TC-15-ATPN Temporary	0.50ha (haul road for OHL installation)	397	2	0.5	Private	IDB	High	Assumptions: Pond depth reduced to 0.5m due to flat elevation. Assumed that this will provide sufficient level difference between pond and receiving watercourse for a gravity connection to the outfall. Notes: FEH point rainfall 630997,163011 used for this area. Next steps: Topographical data of the proposed ditch at the outfall location is required.
TC-16-ATPN Temporary	0.14ha (haul road for OHL installation)	55	2	0.5	Private	IDB	High	Assumptions: Pond depth reduced to 0.5m due to flat elevation. Assumed that this will provide sufficient level difference between pond and receiving watercourse for a gravity connection to the outfall. Notes: FEH point rainfall 630997,163011 used for this area. Next steps:

POND REFERENCE	CONTRIBUTING CATCHMENT AREA (HA)	MINIMUM ATTENUATION VOLUME (M3)	OUTFALL DETAILS					
			DISCHARGE RATE (L/S)	DEPTH OF POND (M)	OWNER	CONSENTING BODY	CONFIDENCE	NOTES
								Topographical data of the proposed ditch at the outfall location is required.
TC-17-ATPN Temporary	0.14ha (haul road for OHL installation)	55	2	0.5	Private	IDB	High	<p>Assumptions: Pond depth reduced to 0.5m due to flat elevation. Assumed that this will provide sufficient level difference between pond and receiving watercourse for a gravity connection to the outfall.</p> <p>Notes: FEH point rainfall 630997,163011 used for this area.</p> <p>Next steps: Topographical data of the proposed ditch at the outfall location is required.</p>
TC-17a-INPN Temporary	0.06ha (haul road for OHL installation)	16.50	2	0.5	Private	IDB	High	<p>Assumptions: Pond depth reduced to 0.5m due to flat elevation. Assumed that this will provide sufficient level difference between pond and receiving watercourse for a gravity connection to the outfall.</p> <p>Notes: FEH point rainfall 630997,163011 used for this area.</p> <p>Next steps: Topographical data of the proposed ditch at the outfall location is required.</p>
TC-17b-ATPN Temporary	0.05ha (haul road for OHL installation)	12.50	2	0.5	Private	IDB	High	<p>Assumptions: Pond depth reduced to 0.5m due to flat elevation. Assumed that this will provide sufficient level difference between pond and receiving watercourse for a gravity connection to the outfall.</p> <p>Notes: FEH point rainfall 630997,163011 used for this area.</p> <p>Next steps: Topographical data of the proposed ditch at the outfall location is required.</p>

POND REFERENCE	CONTRIBUTING CATCHMENT AREA (HA)	MINIMUM ATTENUATION VOLUME (M3)	OUTFALL DETAILS					
			DISCHARGE RATE (L/S)	DEPTH OF POND (M)	OWNER	CONSENTING BODY	CONFIDENCE	NOTES
TC-18-ATPN Temporary	0.21ha (haul road for OHL installation)	96	2	0.5	Private	IDB	High	<p>Assumptions: Watercourse identified through River Stour IDB Mapping. Acceptable to discharge into watercourse through IDB and private owner consenting. Pond depth reduced to 0.5m due to flat elevation. Assumed that this will provide sufficient level difference between pond and receiving watercourse for a gravity connection to the outfall.</p> <p>Next steps: Topographical data of the proposed ditch at the outfall location is required.</p>
TC-19-ATPN Temporary	0.49ha (haul road for OHL installation)	319	2	0.5	Private	IDB	High	<p>Assumptions: Watercourse identified through River Stour IDB Mapping. Acceptable to discharge into watercourse through IDB and private owner consenting. Pond depth reduced to 0.5m due to flat elevation. Assumed that this will provide sufficient level difference between pond and receiving watercourse for a gravity connection to the outfall.</p> <p>Next steps: Topographical data of the proposed ditch at the outfall location is required.</p>
TC-20-ATPN Temporary	0.50ha (haul road for OHL installation)	115	2	0.5	Private	IDB	High	<p>Assumptions: Watercourse identified through River Stour IDB Mapping. Acceptable to discharge into watercourse through IDB and private owner consenting. Pond depth reduced to 0.5m due to flat elevation. Assumed that this will provide sufficient level difference between pond and receiving watercourse for a gravity connection to the outfall.</p> <p>Next steps: Topographical data of the proposed ditch at the outfall location is required.</p>
TC-20a-ATPN Temporary	0.11ha (haul road for OHL installation)	39	2	0.5	Private	IDB	High	<p>Assumptions: Watercourse identified through River Stour IDB Mapping. Acceptable to discharge into watercourse through IDB and private owner consenting.</p>

POND REFERENCE	CONTRIBUTING CATCHMENT AREA (HA)	MINIMUM ATTENUATION VOLUME (M3)	OUTFALL DETAILS					
			DISCHARGE RATE (L/S)	DEPTH OF POND (M)	OWNER	CONSENTING BODY	CONFIDENCE	NOTES
								<p>Pond depth reduced to 0.5m due to flat elevation. Assumed that this will provide sufficient level difference between pond and receiving watercourse for a gravity connection to the outfall.</p> <p>Next steps: Topographical data of the proposed ditch at the outfall location is required.</p>
TC-21-ATPN Temporary	0.27ha (haul road for OHL installation)	135.50	2	0.5	Private	IDB	High	<p>Assumptions: Watercourse identified through River Stour IDB Mapping. Acceptable to discharge into watercourse through IDB and private owner consenting.</p> <p>Pond depth reduced to 0.5m due to flat elevation. Assumed that this will provide sufficient level difference between pond and receiving watercourse for a gravity connection to the outfall.</p> <p>Next steps: Topographical data of the proposed ditch at the outfall location is required.</p>
TC-21a-ATPN Temporary	0.17ha (haul road for OHL installation)	71.50	2	0.5	Private	IDB	High	<p>Assumptions: Watercourse identified through River Stour IDB Mapping. Acceptable to discharge into watercourse through IDB and private owner consenting.</p> <p>Pond depth reduced to 0.5m due to flat elevation. Assumed that this will provide sufficient level difference between pond and receiving watercourse for a gravity connection to the outfall.</p> <p>Next steps: Topographical data of the proposed ditch at the outfall location is required.</p>
TC-22-ATPN Temporary	0.36ha (haul road for OHL installation)	205	2	0.5	Private	IDB	High	<p>Assumptions: Watercourse identified through River Stour IDB Mapping. Acceptable to discharge into watercourse through IDB and private owner consenting.</p> <p>Pond depth reduced to 0.5m due to flat elevation. Assumed that this will provide sufficient level difference between pond and receiving watercourse for a gravity connection to the outfall.</p> <p>Next steps:</p>

POND REFERENCE	CONTRIBUTING CATCHMENT AREA (HA)	MINIMUM ATTENUATION VOLUME (M3)	OUTFALL DETAILS					
			DISCHARGE RATE (L/S)	DEPTH OF POND (M)	OWNER	CONSENTING BODY	CONFIDENCE	NOTES
								Topographical data of the proposed ditch at the outfall location is required.
TC-22a-ATPN Temporary	0.13ha (Temporary)	49.50	2	0.5	Private	IDB	High	Assumptions: Watercourse identified through River Stour IDB Mapping. Acceptable to discharge into watercourse through IDB and private owner consenting. Pond depth reduced to 0.5m due to flat elevation. Assumed that this will provide sufficient level difference between pond and receiving watercourse for a gravity connection to the outfall. Next steps: Topographical data of the proposed ditch at the outfall location is required.

Risk associated with ALL ponds in Kent scheme:

- The development design accounts for fully saturated ground, and the need to dewater groundwater for the installation of any infrastructure required to be built in dry conditions.
- If the landowner and/or consenting body reject the outfall location, a new outfall location and potentially receiving watercourse may need to be identified, which could result in pond being relocated and or pumping to be required.

Subject: Topography assessment in the Substation and Converter Station platforms

1 Topography assessment in the Substation and Converter Station platforms

A preliminary pipeline design has been carried out in this report to inform about the required Finished Floor Level of the new converter station and substation. This will provide an update of the maximum overall height of the scheme to inform the wider design and consenting process.

The FFL of the platforms is defined by the topography of the site, and it is influenced by the drainage of the platform:

- If the site is in a risk of flooding as per the Flood Risk Assessment document, the FRA will set up a minimum FFL to avoid flood risk.
- All drainage within the platform must drain by gravity into the discharge point. The discharge point must be identified early stages to ensure the drainage can discharge by gravity according to the FFL of the platform defined in the FRA.
- If the proposed site is an extension of an existing substation, the FFL will meet the existing substation level.

This assessment provides a pipeline design to inform about the minimum FFL for the converter and substation platform based on an assessment of the internal drainage of the substation and converter station platform.

The converter station and substation sites are on the Minster Marshes, and both drainage networks discharge into the Minster Stream IDB.

The topographical survey by 3D Engineering Surveys provides an elevation of the base of the watercourse and the top of the embankment of the Minster Stream, which is consistent along the entire length of the Minster Stream IDB within the Minster Marshes:

- Top of the Minster Stream IDB embankment is approx. +1.95mAOD,
- bottom of the Minster Stream IDB watercourse is +0.0mAOD; and
- permanent assumed water level is +1.0mAOD in the Minster Stream IDB.

Based on the above information, a permanent water level of 1m is assumed in the IDB watercourse. Therefore, all outfalls into the Minster Stream IDB are set to an IL (Invert Level) of +1.2mAOD, which provides a minimum vertical clearance of 200mm from the (assumed) permanent water level.

The depth of ponds in the Minster Marshes is limited to 0.5m to reduce the excavation depth in the Minster Marshes.

1.1 Converter Station catchment

It is divided in two catchments (eastern and western catchment) as it is crossed by an existing watercourse that will be diverted. The eastern and western converter catchments discharge into the Minster Stream IDB watercourse via two outfalls as per the Qbar rates of each catchment. The reason behind dividing the converter station in two catchments is that the drainage strategy of the converter station should mimic the existing ground runoff, to replicate the current state and avoid significantly altering the flows received by the Minster Stream IDB watercourse.

The eastern catchment is the biggest converter station catchment, so it will contain the longest piped network for the converter station. To facilitate a gravity connection from the internal drainage network to the outfall in the IDB watercourse, a minimum FFL for the converter station is proposed in this section.

This drainage strategy does not design the internal pipe drainage networks of the new converter station, but by using the min FFL of the platform, a high-level assessment of the longest pipe network that belongs the outfall to the Minster Marshes is proposed below for this assessment:

- IL of the Outfall is +1.2m AOD. This outfall is Outfall PC-9-ATPN shown in Appendix D.
- A 150mm diameter outfall pipe is proposed from the base of the pond to the watercourse. This pipe is 10m approx. and is laid at 1 in 100 gradient.
- A gravity connection from the pond outlet towards the adjacent watercourse is proposed as follows:
 - The following formula is proposed to calculate pipe Invert Levels (IL):
 - $IL_{\text{downstream}} + \text{Pipe outfall Distance} * \text{Gradient} = IL_{\text{upstream}}$.
 - $IL_{\text{outfall in IDB watercourse}} + \text{Pipe outfall Distance (from outfall to the IL outlet of the pond)} * \text{Gradient} = \text{pond base elevation}$:
 - $+1.2\text{mAOD} + 10\text{m} * 1 / 100 = +1.3\text{mAOD}$.
 - For this assessment the base of the pond = IL pond inlet = IL pond outlet. It is assumed that the inlet and outlet basin are at the base of the pond with a depth of 0.5m. Usually, the pond inlet sits above the pond outlet to avoid the silt blocking the outlet of the pond if little maintenance occurs.
- A pipe network profile (the longest within the converter station platform, from the pond inlet to the furthest manhole within the converter station) shows a 260m pipe length (see Figure 1.1). This high-level assessment assumed a single pipe diameter for the longest pipe network. The pipe diameter is 300mm and the pipe is laid at 1 in 225 gradient.
 - It is calculated based on the IL Pond Inlet + Longest pipe network (from the furthest manhole to the inlet of the pond) * Gradient = IL of the furthest manhole (upstream):
 - $+1.3\text{mAOD} + 260\text{m} * 1 / 225 = +2.45\text{mAOD}$.
 - The IL of the furthest manhole within the converter station connected to the inlet of the pond is +2.45mAOD.
- The Cover Level (CL) of the manhole should be at least 1m above the IL to protect the pipe against vehicle loading, so the furthest manhole $CL = 2.45\text{mAOD} + 1\text{m} = 3.45\text{mAOD}$ which is therefore the minimum FFL of the platform to ensure a gravity connection of the converter drainage network towards the adjacent outfall in the IDB watercourse.
- This assessment is based on the longest pipe run within the converter station platform, from the pond inlet to the furthest manhole within the converter station and relies on the inlet and outlet of the pond being at the same elevation.

This assessment indicates the minimum FFL for the Converter Station should be +3.45mAOD to provide a gravity connection of the converter station internal drainage to the proposed outfall into the adjacent watercourse. Existing ground levels is approximately between 1.32 -1.56mAOD for converter station, which suppose a maximum of 2m ground raising for the converter station platform.

Figure 1.1: Indicative longest pipe network for the converter station

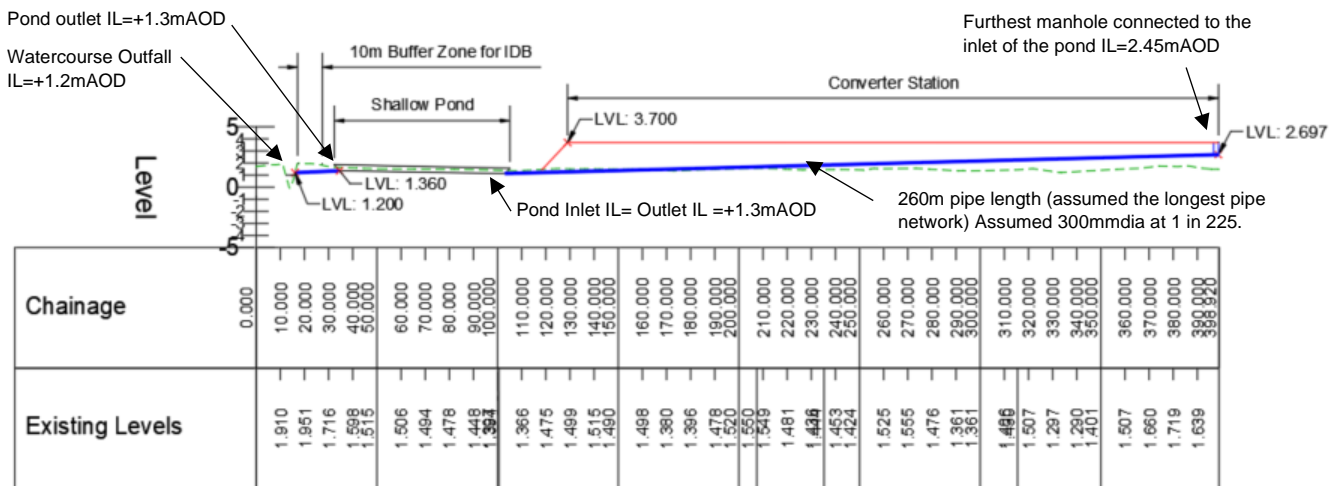

Notes: Blue line indicates the longest pipe network within the converter station platform. Red Line denotes the FFL of the platform. Green dashed line denotes existing ground.

Source: Mott MacDonald.

1.1.1 Substation catchment

The substation station discharges into an ordinary watercourse as per Qbar via a single outfall. There is a single catchment that cover the substation footprint.

The proposed substation drainage discharges into an ordinary watercourse, which is hydraulically connected to the Minster Marshes IDB watercourse. This ordinary watercourse shows a similar topography as the IDB watercourse, as they are both within the same marshes.

This drainage strategy does not design the internal pipe drainage networks of the new substation, but by using the min FFL of the platform, a high-level assessment of the longest pipe network that belongs the outfall to the Minster Marshes is proposed below for this assessment:

- Permanent Outfall for PC-10-ATPN: IL of the Outfall is assumed +1.2m AOD.
- A pipe of 150mm diameter is proposed from the pipe outfall to the outlet of the pond. This pipe is 10m approx., and it is laid at 1 in 100 gradient.
- A gravity connection from the pond outlet towards the adjacent watercourse is proposed as follows:
 - IL outfall in IDB watercourse + Pipe outfall Distance (from outfall to the IL outlet of the pond) * Gradient = pond base elevation:
 - $+1.2mAOD + 10m * 1 / 100 = +1.3mAOD$.
- A pipe network profile (the longest within the substation platform, from the pond inlet to the furthest manhole within the substation) shows a 150 pipe length (see Figure 1.1). This high-level assessment assumed a single pipe diameter for the longest pipe network. The pipe diameter is 300mm and the pipe is laid at 1 in 225 gradient.
 - It is calculated based on the IL Pond Inlet + Longest pipe network (from the furthest manhole to the inlet of the pond) * Gradient = IL of the furthest manhole (upstream):
 - $+1.2mAOD + 150m * 1 / 225 = +1.87mAOD$.
 - The IL of the furthest manhole within the substation connected to the inlet of the pond is +1.87mAOD.
- The Cover Level of the manhole should be at least 1m above the IL to protect the pipe against vehicle loading, therefore the $CL = 1.87mAOD + 1m = 2.87mAOD$ which is therefore the FFL of the

platform to ensure a gravity connection of the substation drainage network towards the adjacent outfall in the watercourse.

- This assessment is based on the longest pipe run within the converter station platform, from the pond inlet to the furthest manhole within the converter station and relies on the inlet and outlet of the pond being at the same elevation.

This assessment indicates the minimum FFL for the Substation should be +2.87mAOD to provide a gravity connection of the converter station internal drainage to the proposed outfall into the adjacent watercourse. Existing ground levels is approximately +1.4mAOD for substation, which suppose a maximum of 1.5m ground raising for the substation platform.

Figure 1.2: Indicative longest pipe network for the substation

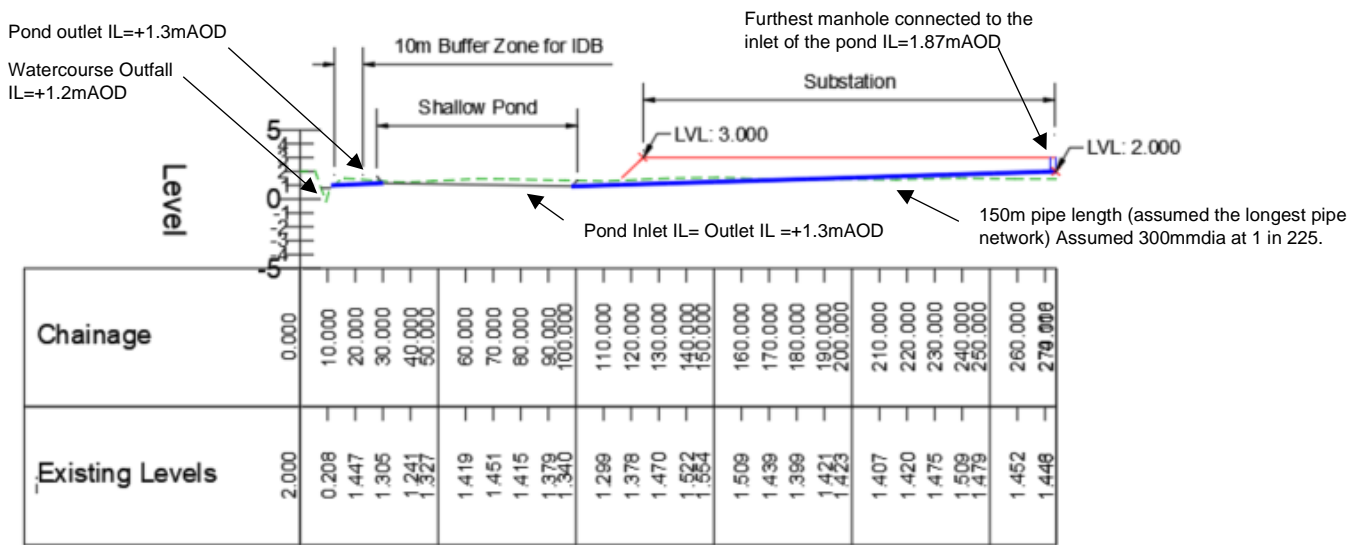

Notes: Blue line indicates the longest pipe network within the converter station platform. Red Line denotes the FFL of the platform. Green dashed line denotes existing ground.

Source: Mott MacDonald.

Figure 1.3: Converter Station and Substation Drainage Plan (Extract) that indicates the alignments for the longest pipe run in the substation and converter station.

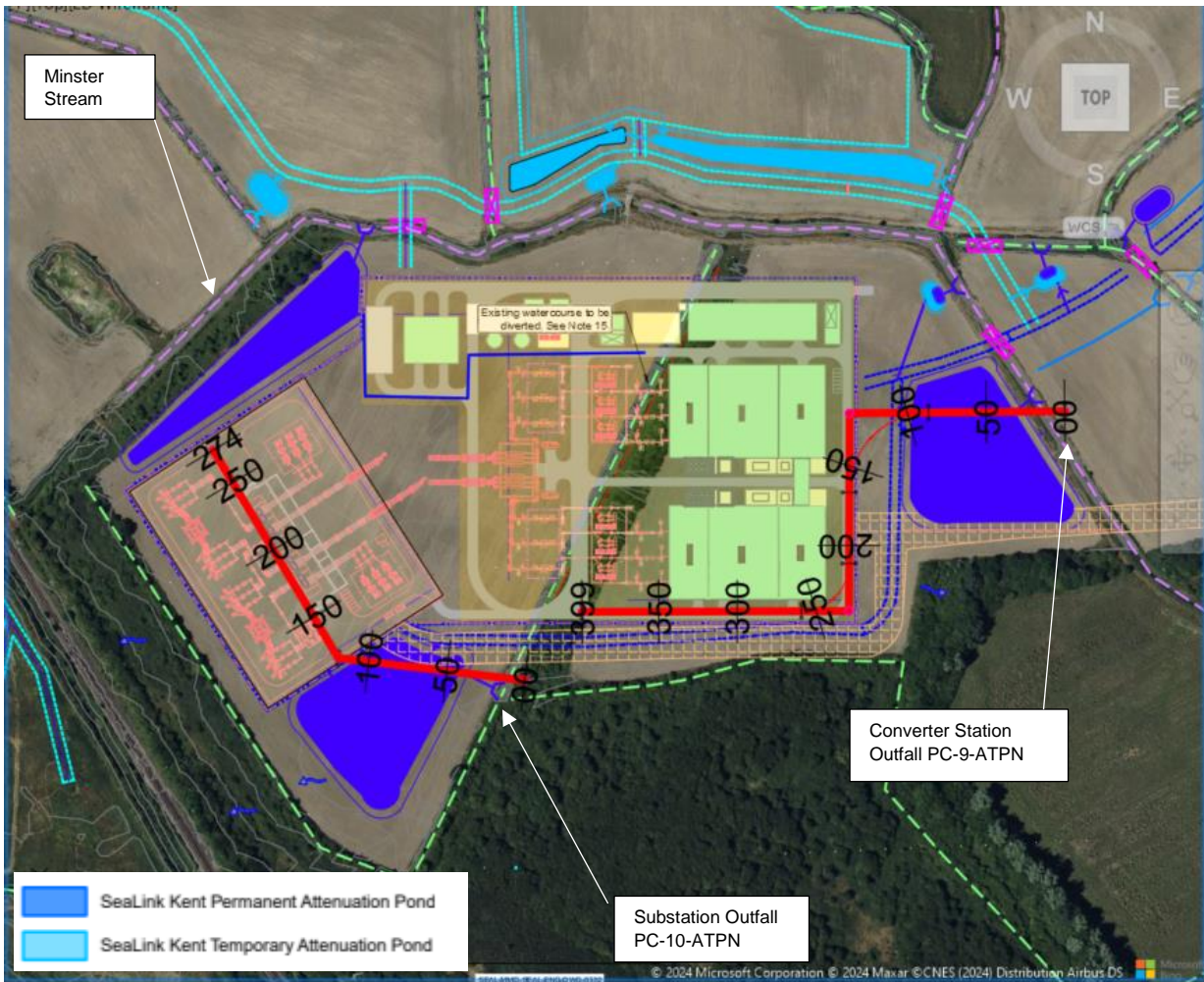

Notes: Dark blue line indicates the permanent drainage network. Light blue line indicates the temporary drainage network. Red Line denotes the FFL of the platform. Green dashed line denotes an ordinary watercourse. Purple dashed line denotes the IDB watercourse. Red lines denote the pipe network alignments shown in Figure 1.1 and Figure 1.2.

Source: Mott MacDonald

Appendix B Drainage Layouts

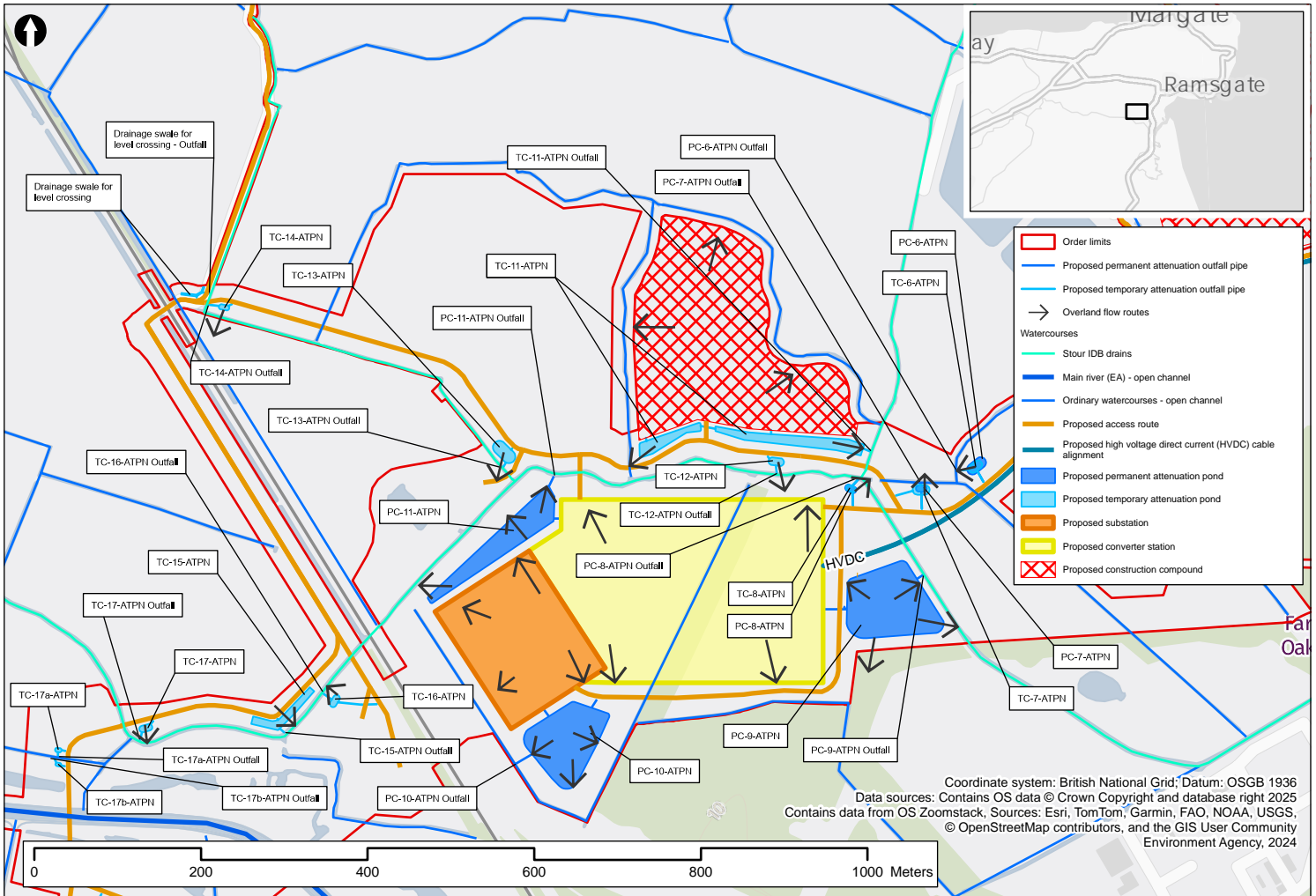

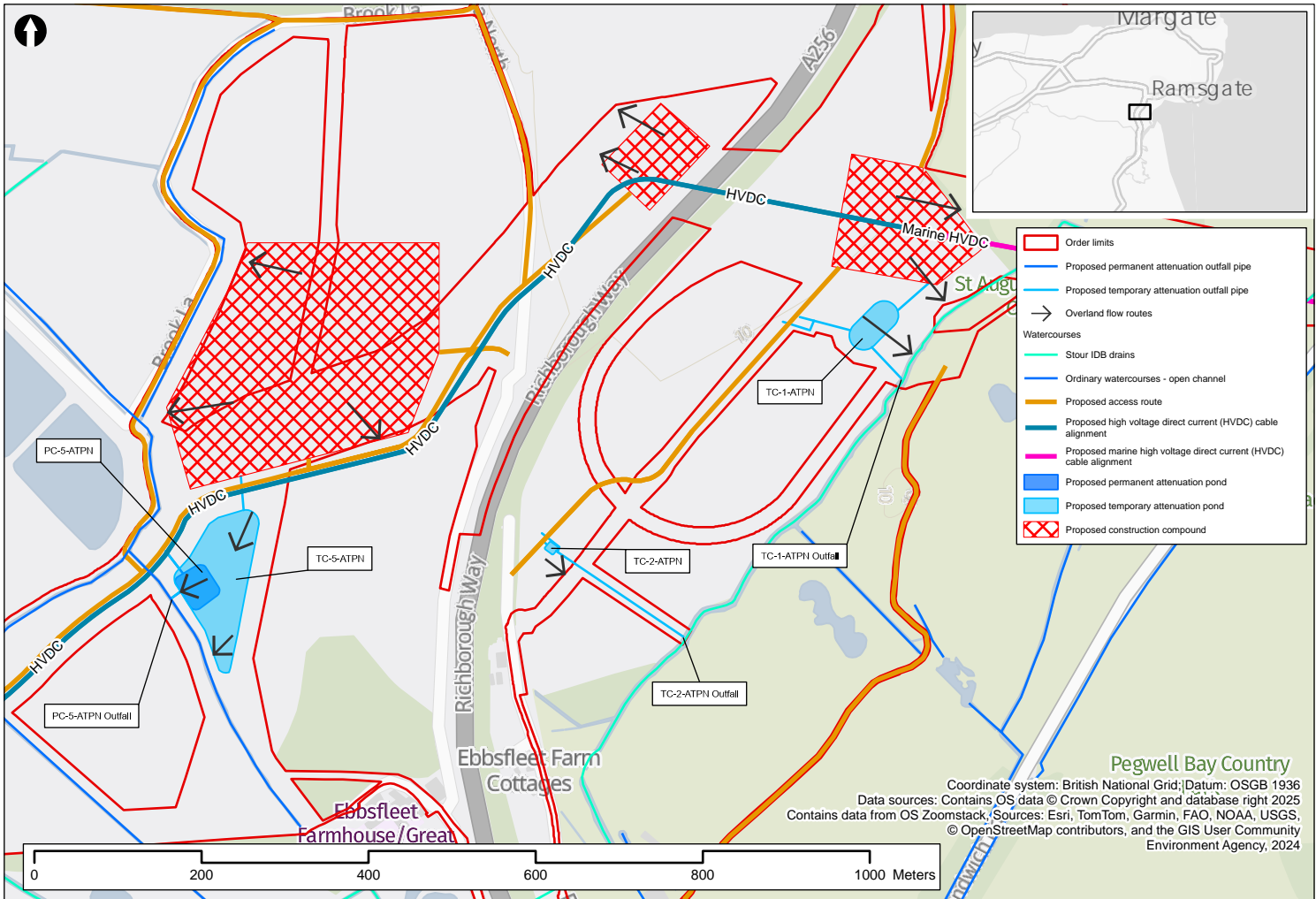

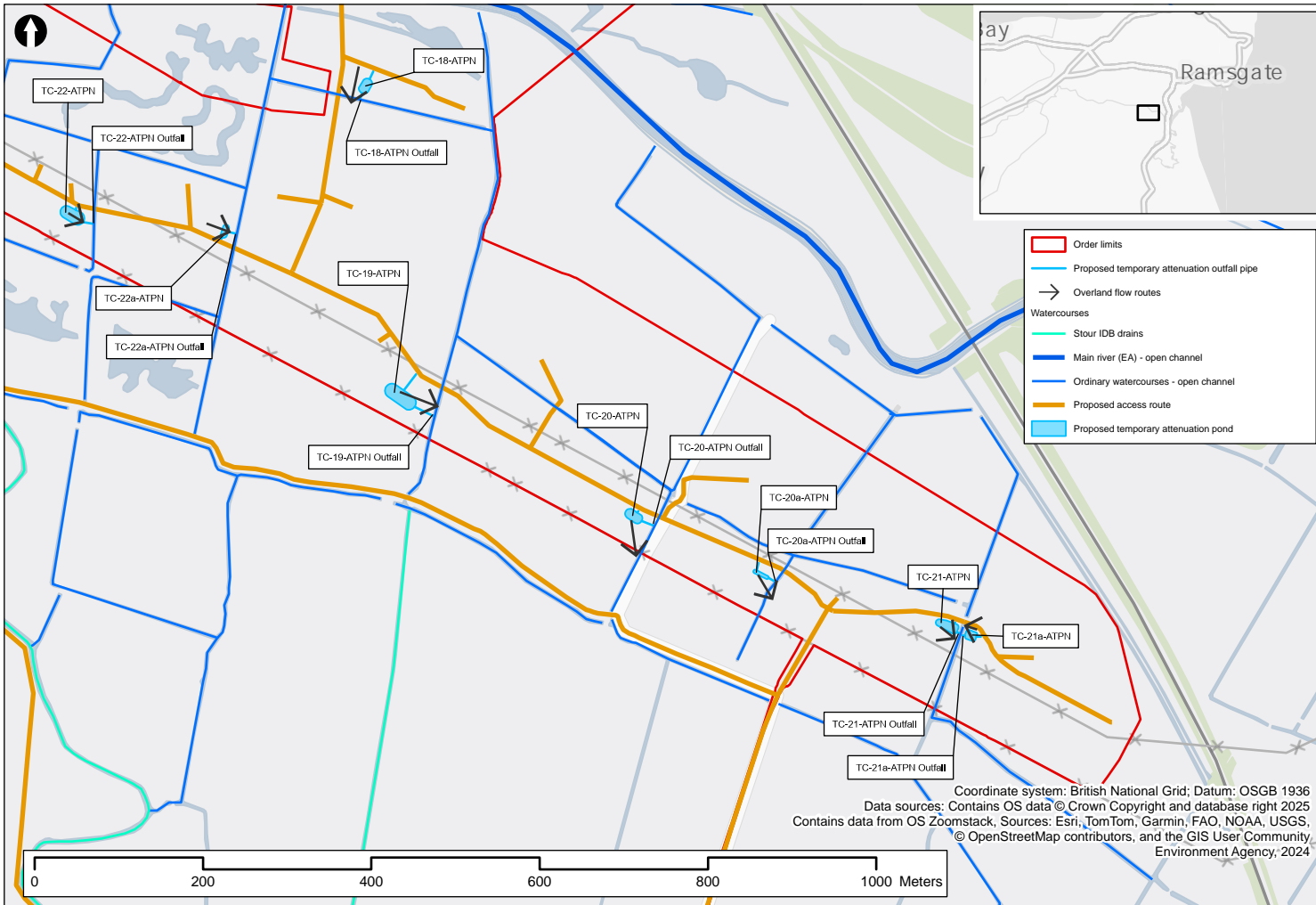

Notes

- This plan is scaled at paper size A1, therefore any prints taken at smaller sizes will affect accuracy of the measurement units and should not be scaled against.
- These plans will sit within the Order Limits. Due to the need for future flexibility, National Grid will be applying for Order Limits and Limits of Deviation within its Development Consent Order, within which any final alignment would lie. Therefore, all aspects of the authorised development, including the cable alignment, converter stations, substations and pylon locations should be treated as indicative only.
- For further information on construction please refer to the construction section of the Environmental Statement.
- For further information refer to the Drainage Strategies (Document Ref 9.17.1 and 9.17.2).
- Legal easements and non planting zones will be included in further design development.
- Reference should be made to the Guide to the Plans (Document Ref 2.1) which provides further information on what the plans show.

TYPICAL DETENTION BASIN PLAN

NTS

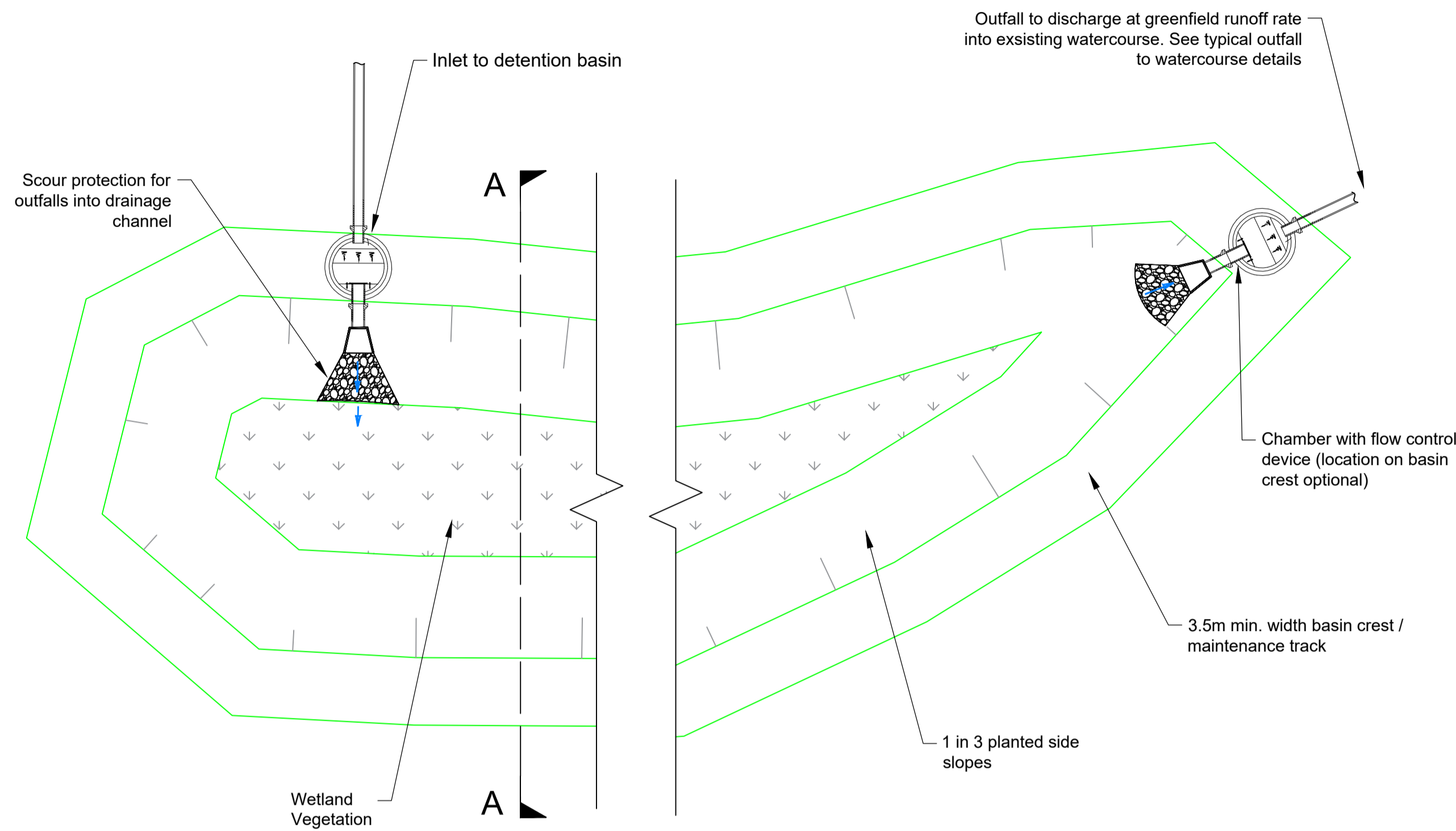

SECTION OF OUTLET HEADWALL FROM DETENTION BASIN

Scale 1:20

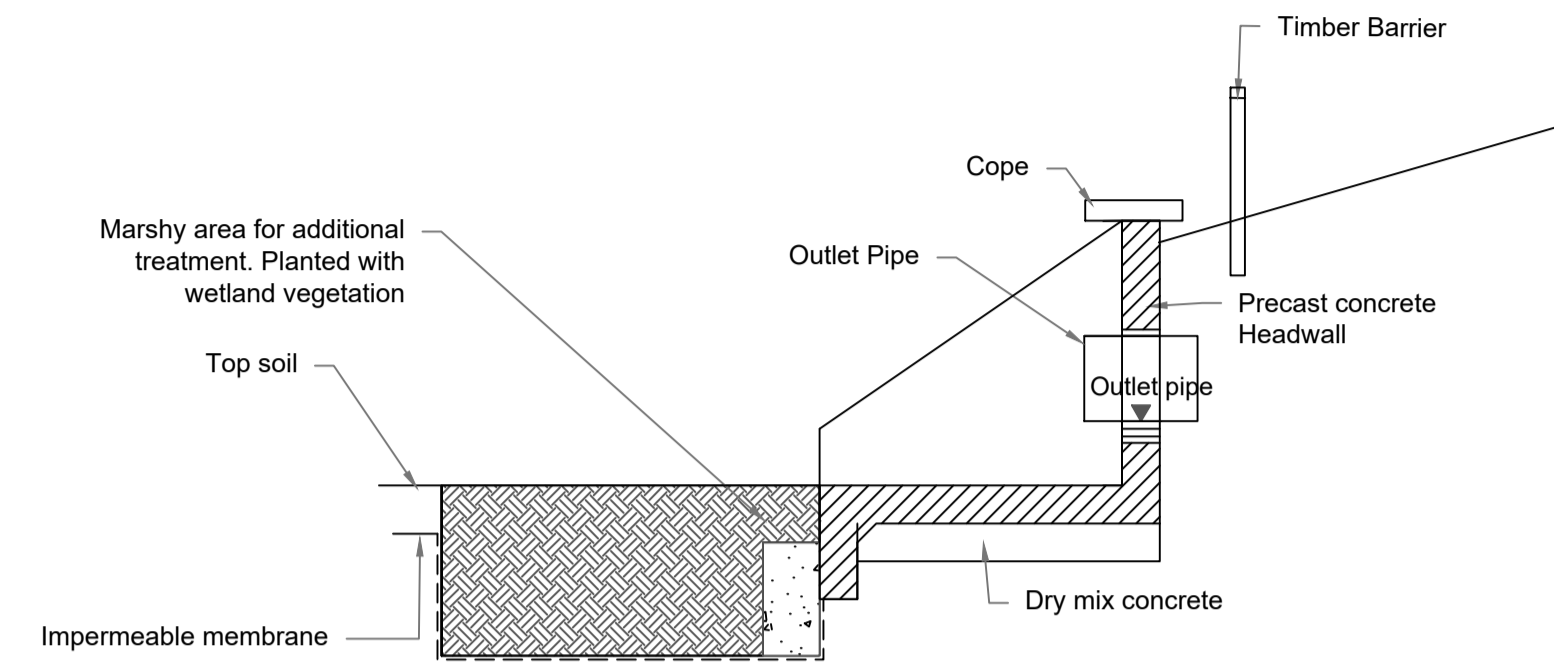

SECTION OF INLET HEADWALL INTO DETENTION BASIN

Scale 1:20

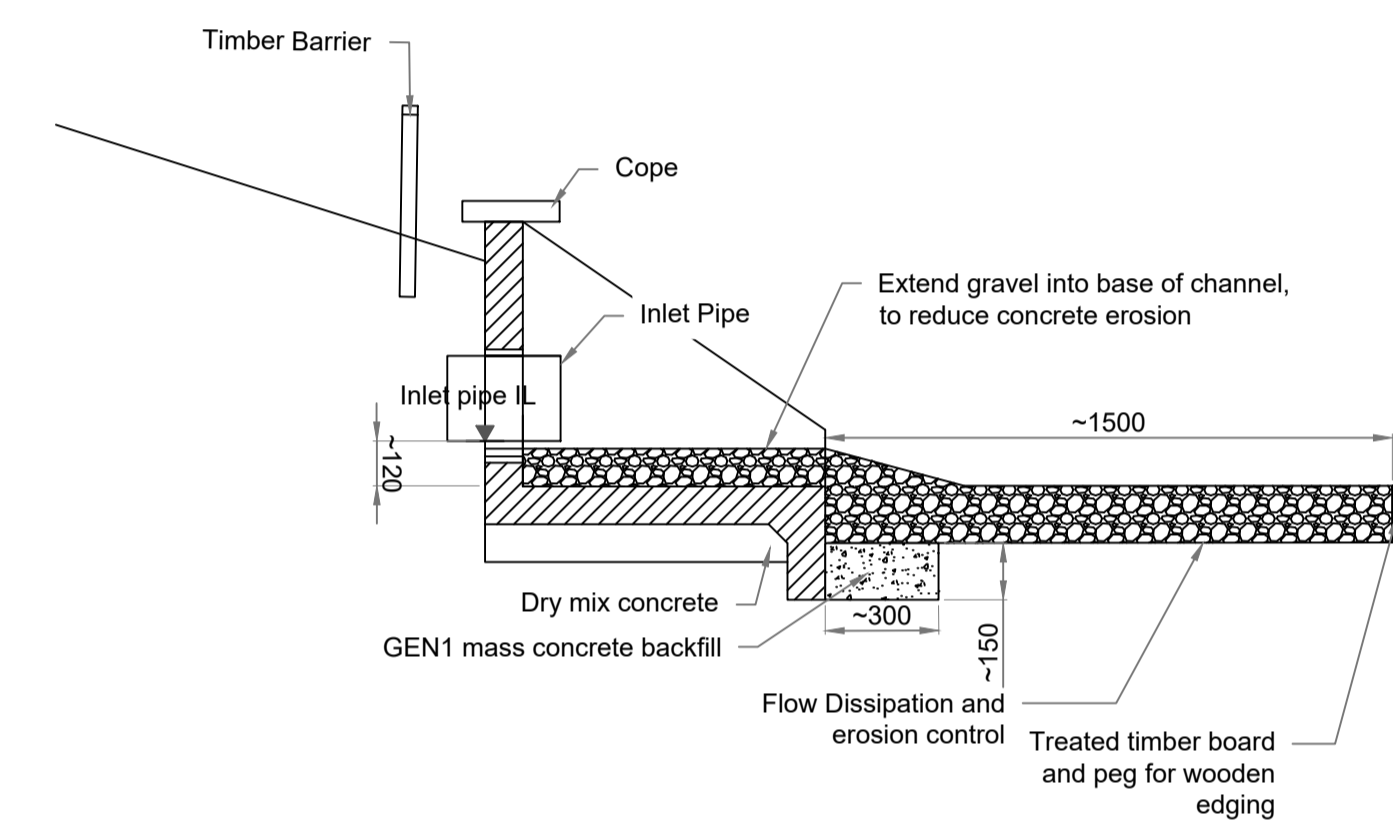

TYPICAL DETENTION BASIN SECTION (SECTION A-A)

NTS

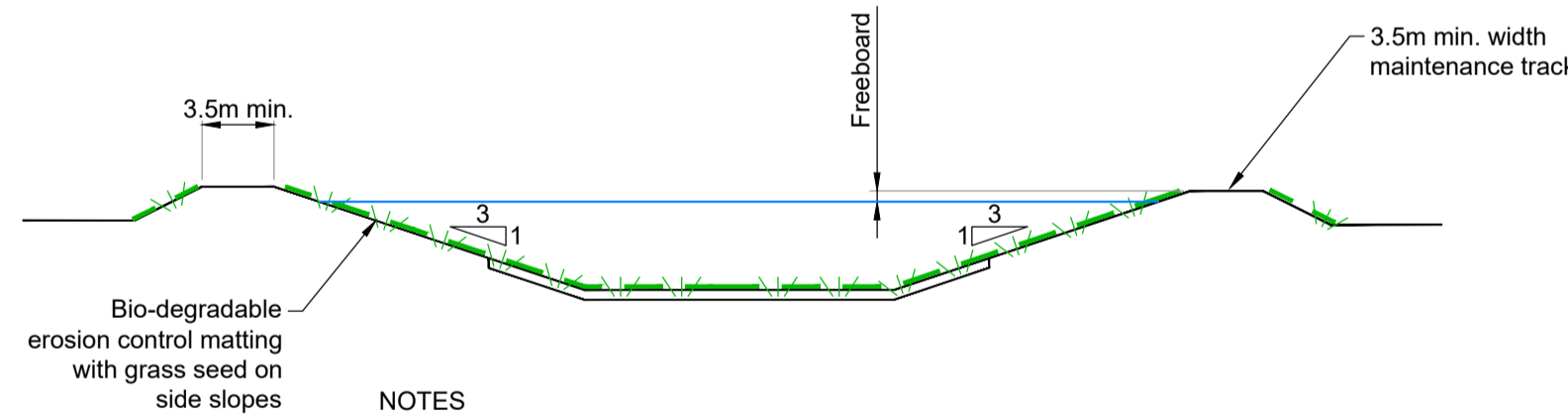

NOTES

- Side slopes and dimensions as noted in Drainage Strategy (Ref. 9.17.1 and 9.17.2).
- Bio-degradable erosion control matting to be installed where required.
- Profile of basin to have natural rounded transition between base, side slopes and adjacent ground.

TYPICAL DETAIL OF OUTFALL TO ROAD DITCH

Scale 1:20

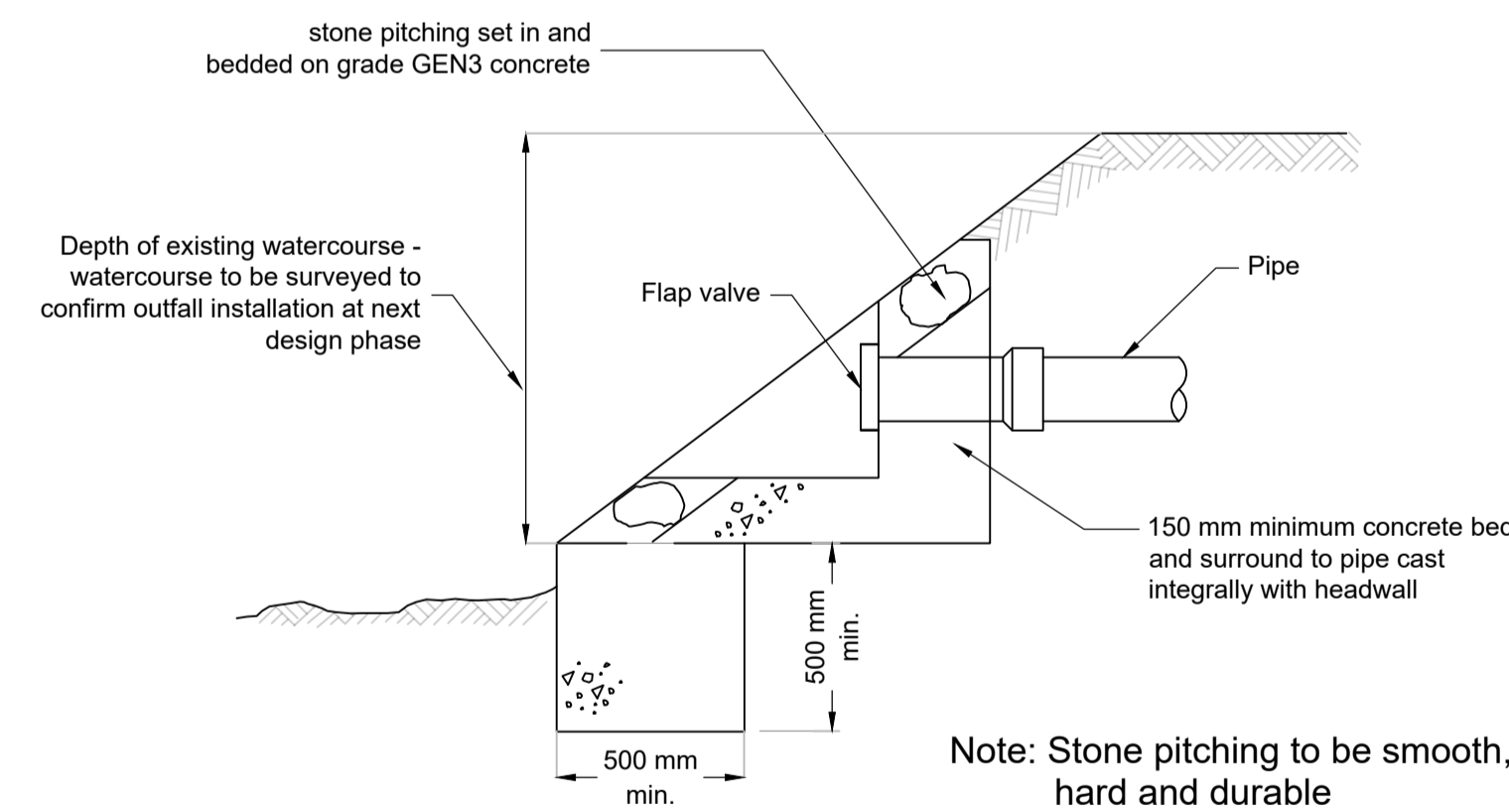

Note: Stone pitching to be smooth, hard and durable

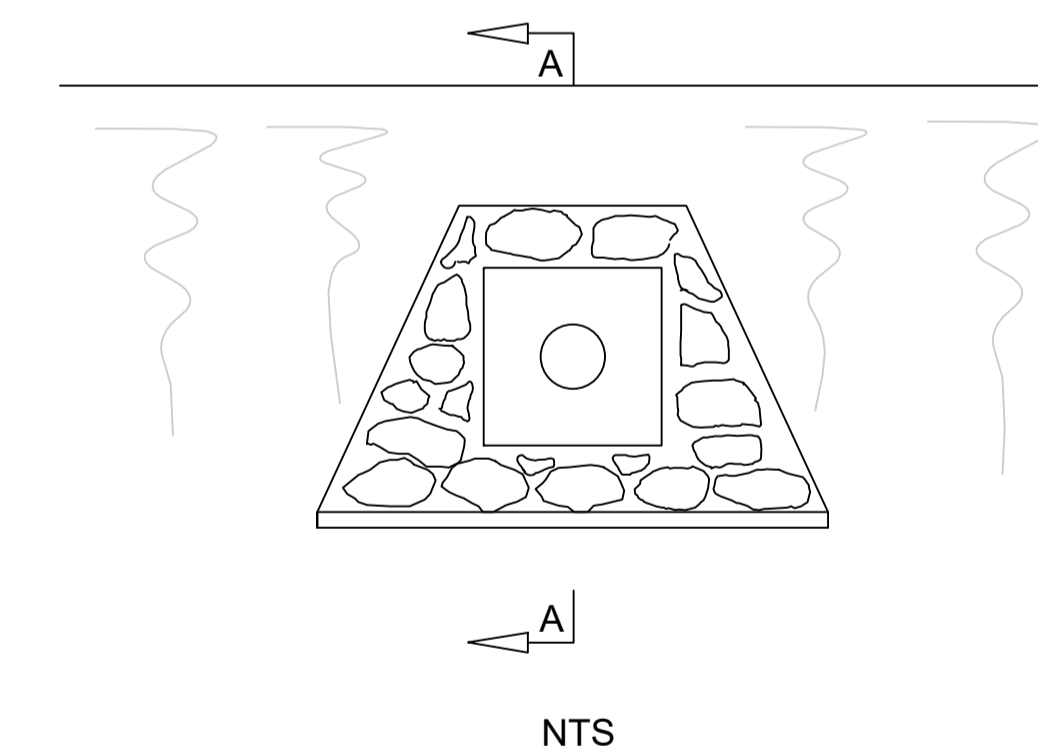

TYPICAL DETENTION BASIN LONG SECTION

NTS

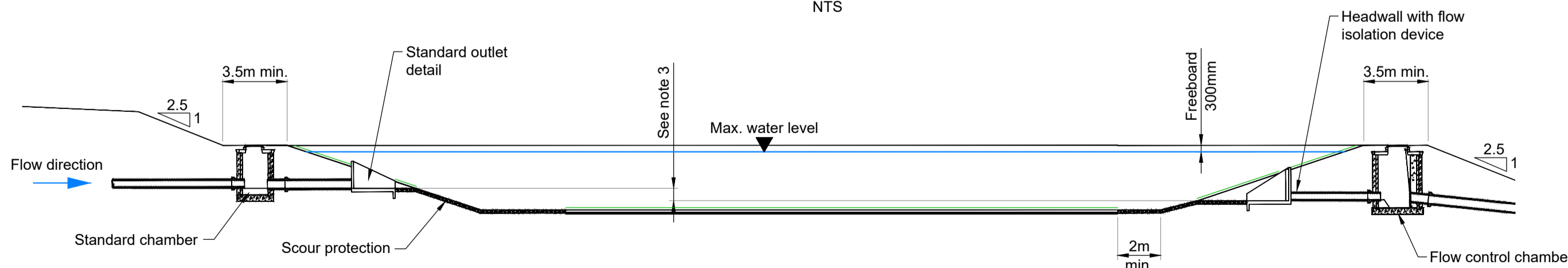

NOTES

- Side slopes and dimensions as noted in Drainage Strategy (Ref. 9.17.1 and 9.17.2).
- Profile of basin to have natural rounded transition between base, side slopes and adjacent ground.
- Difference between inlet and outlet levels should be sufficient to ensure that basin drains as intended (typically 0.5% along flow path).

SECTION A-A

TYPICAL DRAINAGE SWALE SECTION DETAIL

Scale 1:20

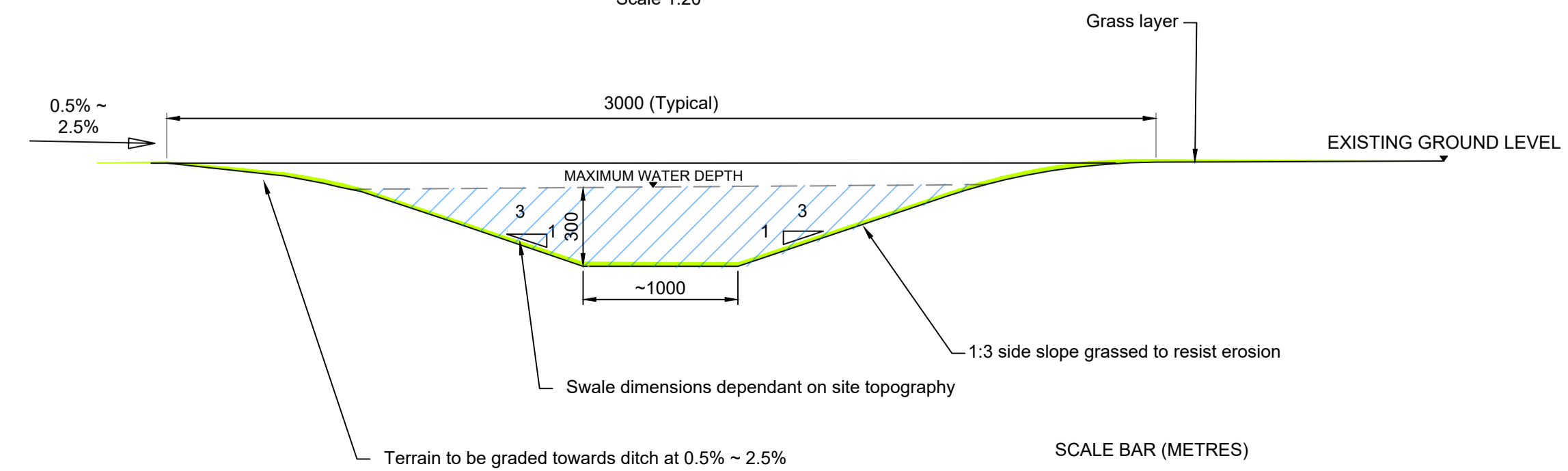

SCALE BAR (METRES)



Legend

Illustrative as shown

Abbreviations:

- FFL - Finished Floor Level
- C.L. - Cover Level
- NTS - Not To Scale

Sheet X Centroid Coordinate: Sheet Y Centroid Coordinate:

Issue	Date	Remarks	Drawn	Checked	Approved
A	23/02/2026	For Submission	AW	LS	JW

**THE NATIONAL GRID (SEA LINK) ORDER
 PINS APPLICATION NUMBER: EN020026
 TYPICAL DRAINAGE DETAILS
 SHEET 1 OF 1**

nationalgrid

Application Number: EN020026

National Grid Drawing Reference: SEAL-MMD-SEAL-ENG-DWG-0817

Scale	Sheet Size	Sheet	Issue
AS SHOWN	A1	SHEET 1 OF 1	A

Appendix C Additional Insets

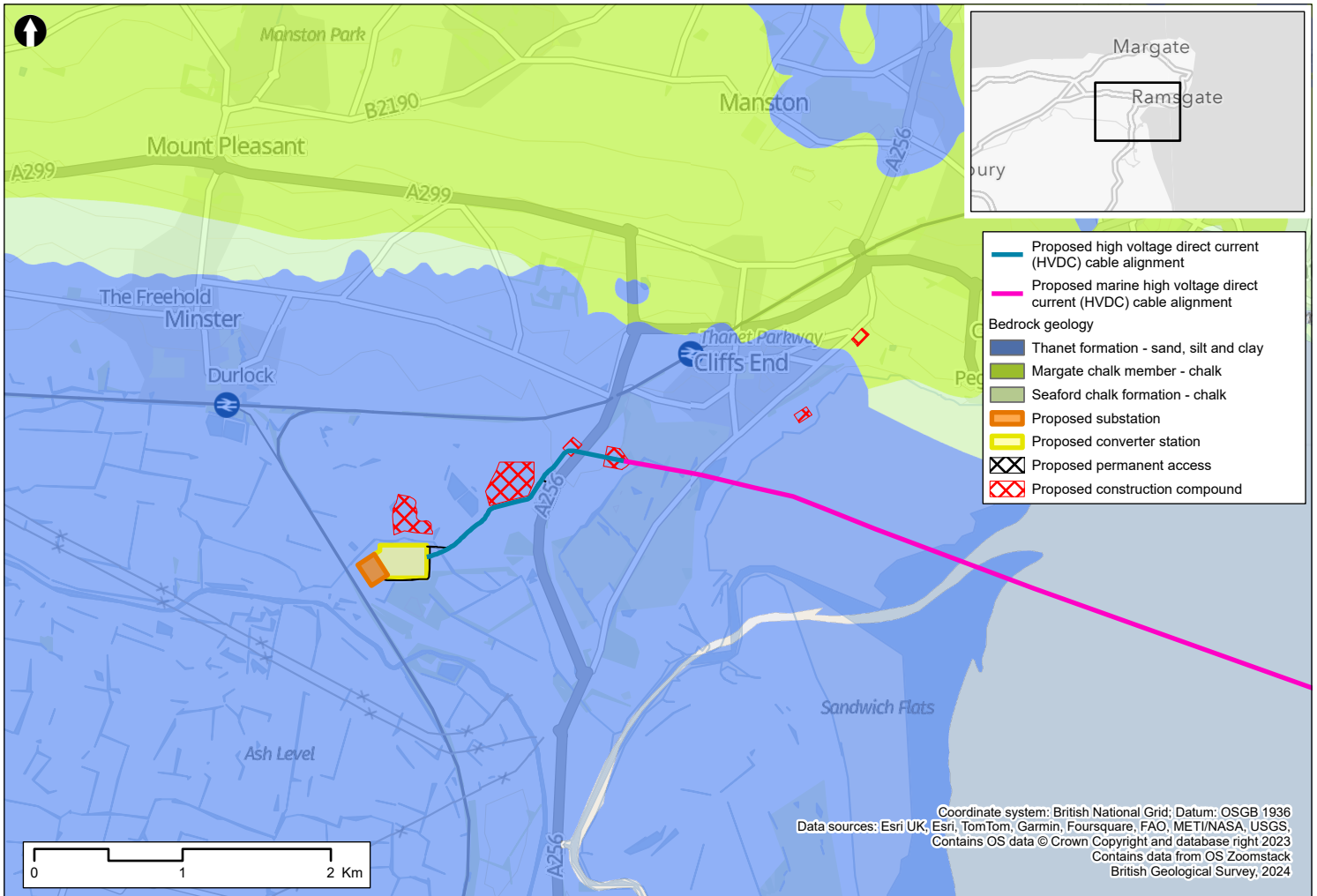

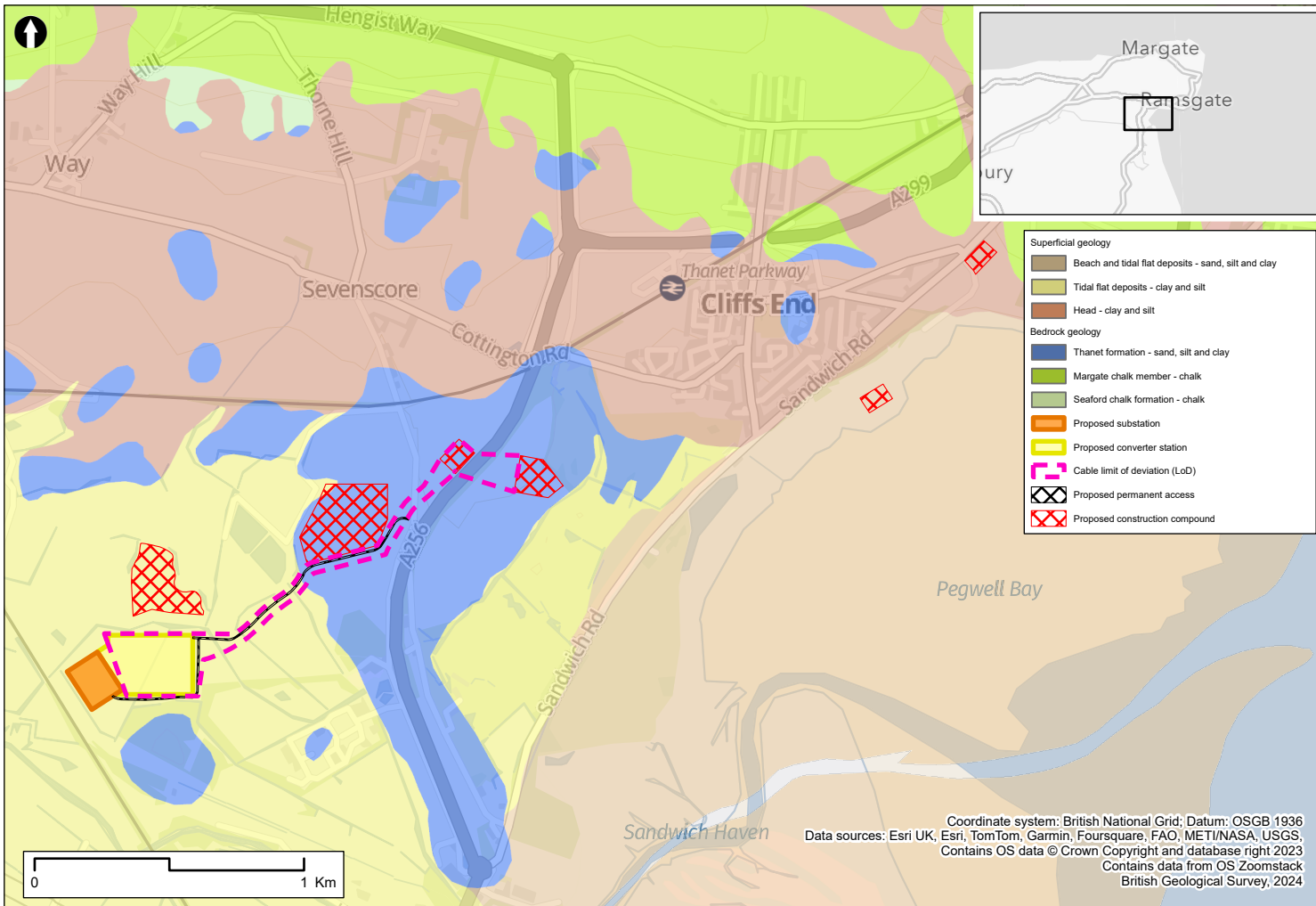

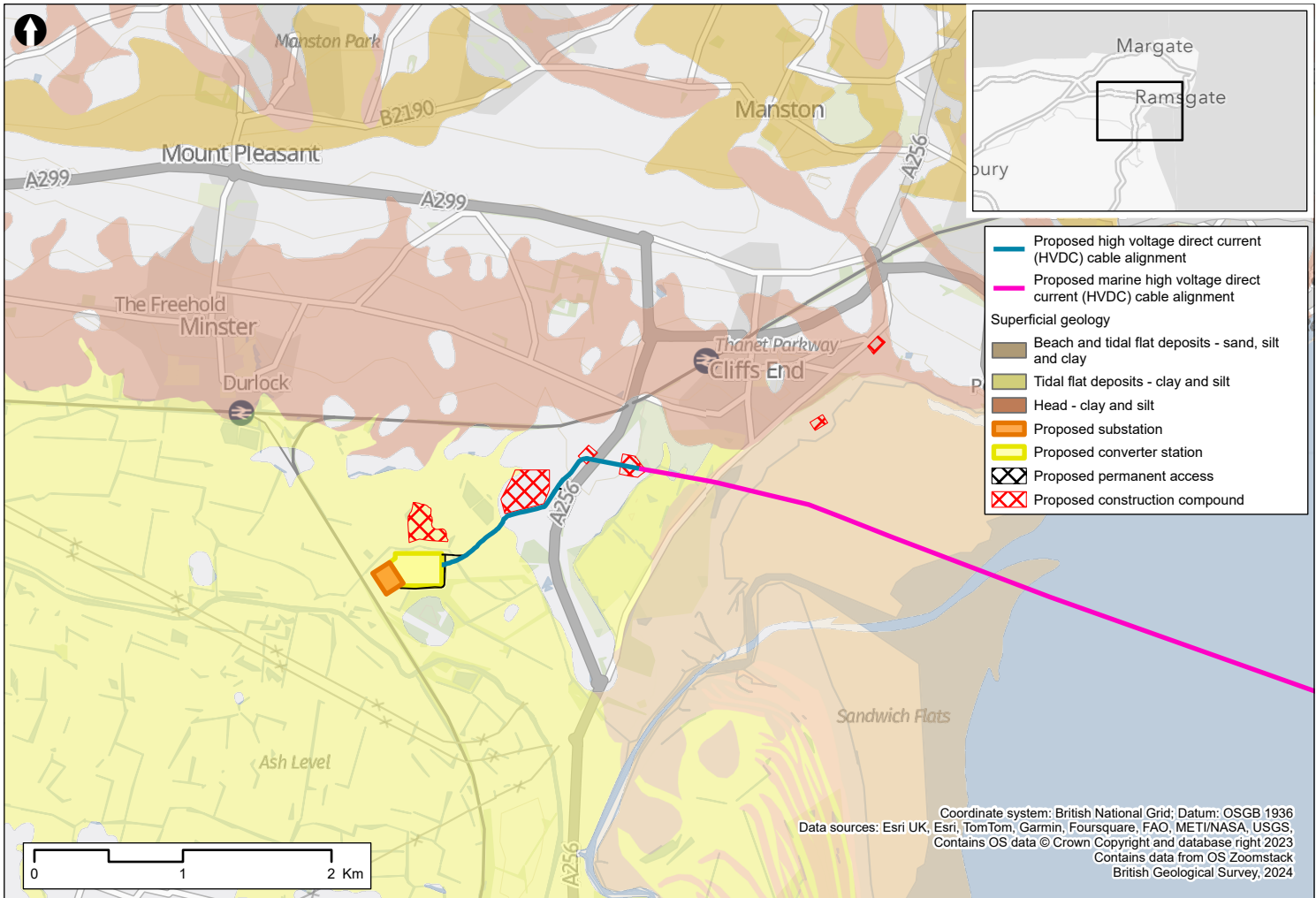

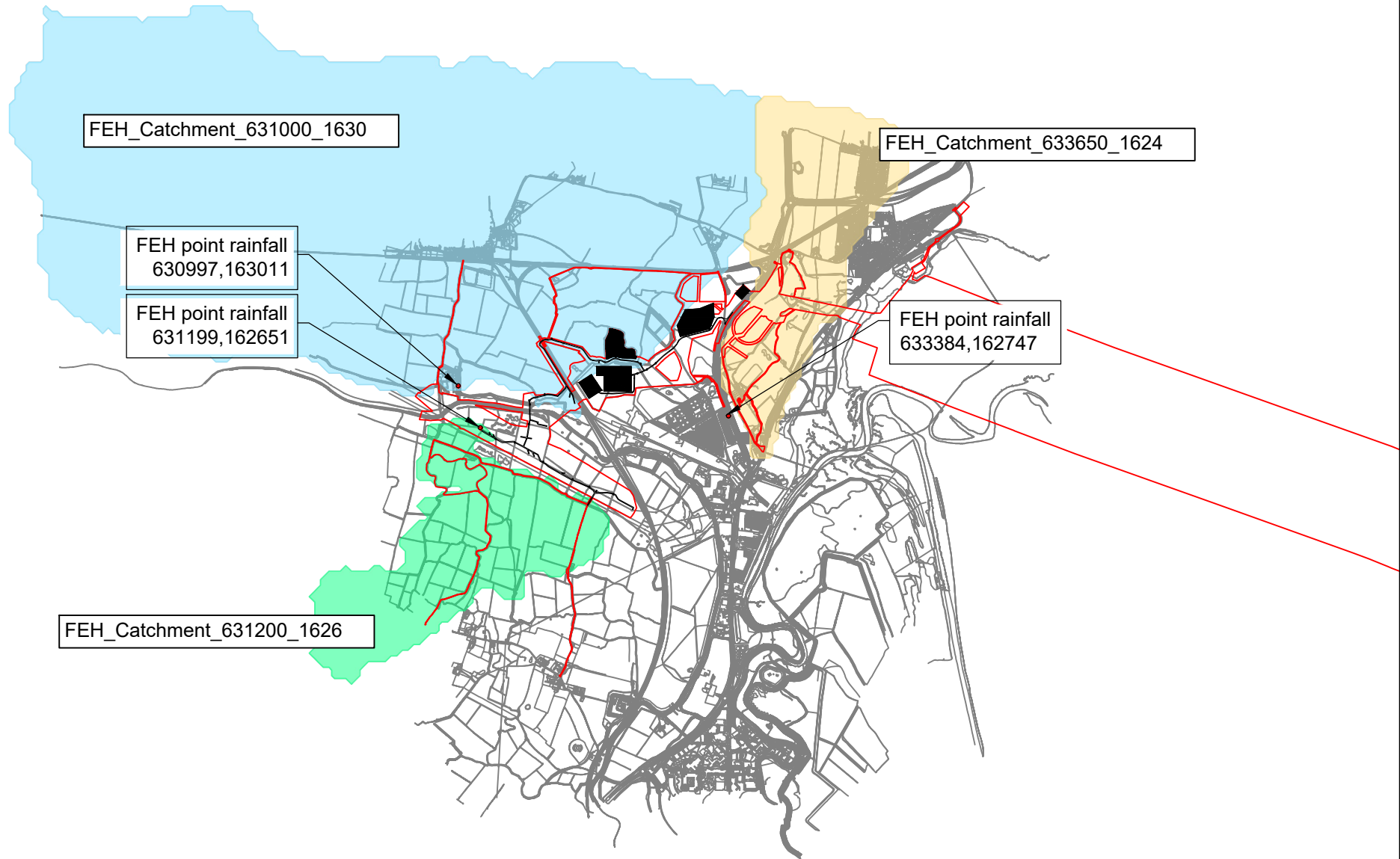

Appendix D Consultation Responses

This appendix covers a summary of those statutory consultation responses that have been received from 2022 to 2024, as a response of the initial engagement during August 2022 with the different consultees. Note that there may be updates to this information during examination, which will be recorded in the Statements of Common Ground for the appropriate stakeholder.

- August 2022 / Sea Link – Kent Interface with Environment Agency (Kent) regarding crossing of rivers. SEAL-MMD-SEAL-ENG-TCN-0403.
- August 2022 / Sea Link – Kent Interface with River Stour IDB regarding crossing of rivers. SEAL-MMD-SEAL-ENG-TCN-0404.
- August 2022 / Sea Link – Kent Interface with Kent County Council regarding crossing of rivers. SEAL-MMD-SEAL-ENG-TCN-0405.

A summary of the responses from stakeholders and regard with the Drainage Strategy design have been captured in Table D1.

Details of the minutes from the drainage stakeholder engagement meetings with the relevant water authorities are recorded in the documents:

- Memorandum of Understanding Environment Agency (Kent) SEAL-MMD-SEAL-ENG-REP-0476 dated July 2023.
- Memorandum of Understanding River Stour IDB SEAL-MMD-SEAL-ENG-REP-0480 dated November 2022.

A Section 42 consultation for the proposed Sea Link project was conducted during 2023-2024. The summary of the comments and actions which were specific to the Sea Link project are included in Table D1.

Table D.1 Consultation responses in relation with the drainage strategy report

Consultee	Date/ Document	Comment	Response / where addressed in the Drainage Strategy report
EA Kent	<p>August 2022 / Sea Link – Kent Interface with Environment Agency regarding crossing of rivers. SEAL- MMD-SEAL- ENG-TCN- 0403.</p> <p>October 2022 / River Crossing Consultation with EA. AC/2022/1313 36/01-L01.</p> <p>July 2023 / Memorandum of Understanding - Environment Agency (Kent) / SEAL-MMD- SEAL-ENG- REP-0476.</p>	<p>EA have a national no culverting policy due to their negative impacts on fish movements and other aquatic ecology and potential hydro-geomorphological effects. Therefore, EA object to the proposed construction of culverts in principle and would only consider clear span bridges.</p> <p>More information required detailing the potential impacts of the proposed construction works and post construction activities may have on the species and habitats within the river corridor, including the buffer zone. The applicant will need to carry out and submit an ecological survey and impact report, covering all sections where there are plans to cross Main River, prior to the development of any detailed plans.</p> <p><u>Crossing Location:</u> We have no objection to the principle of a crossing at this location however we will need to discuss the impact the temporary works will have on Environment Agency access. Marsh Farm Road Bridge is an Environment Agency asset, and we will need to be notified if and when our access will be compromised during construction. This will also apply to Southern Water.</p> <p><u>Cable Crossing Method:</u> All main river crossings would require a form of permission from</p>	<p>River Stour River is not crossed by the cable route. River Stour is crossed by OHL. A new temporary bridge is required on the River Stour for the installation of the new OHL.</p>

Consultee	Date/ Document	Comment	Response / where addressed in the Drainage Strategy report
		<p>the Environment Agency, either by obtaining a Flood Risk Activity Permit (FRAP) or by registering a permit exemption.</p> <p>Horizontal Directional Drilling (HDD) is our preferred method. If HDD is chosen, the applicant is likely to be able to register for a permit exemption and a FRAP is unlikely to be required.</p> <p>The open cut method will require a bespoke Permit and details should be discussed with the relevant PSO Team.</p> <p><u>Design Criteria:</u></p> <p>The Environment Agency's climate change guidance states that development classed as 'essential infrastructure' should be designed using 1% AEP (1 in 100 year) flood flows plus the 'higher central' climate change allowance (appropriate for essential infrastructure) for the epoch that most closely represents the lifetime of the development.</p> <p>For the temporary works with a design lifetime of approximately 5 years, it would be sufficient to use present day flows.</p>	
Lead Local Flood Authority (Kent County Council)	August 2022 / Sea Link – Kent Interface with Kent County Council regarding crossing of rivers.	<p><u>Discharge Rates for Surface Water Drainage:</u></p> <p>This will be dependent on size of catchment upstream of the flow control device</p> <p>2l/ha/s typical discharge rate into IDB watercourses</p> <p><u>Reinstatement:</u></p>	Temporary SuDS designed and built for the construction phase only must be designed to manage runoff for all events up to and including the 1in30 (1%) AEP storm plus 20% allowance for climate change.

Consultee	Date/ Document	Comment	Response / where addressed in the Drainage Strategy report
River Stour IDB	<p>SEAL-MMD- SEAL-ENG- TCN-0405.</p> <p>Initial Review Meeting / 24th January 2023</p> <p>Water Environment Thematic Meeting / 6th February 2024</p> <p>August 2022 / Sea Link – Interface with River Stour Internal</p>	<p>Watercourses and land to be returned to previous condition.</p> <p><u>Consenting:</u> Any works within 8m radius of IDB maintained watercourse requires consent. Temporary and permanent crossings over IDB watercourses – ideally bridged but culvert pipe/box maintaining channel capacity would suffice. Mammal ledges are required.</p> <p><u>Culvert size:</u> Temporary - large as possible to avoid reduction in capacity. Minimum area 600x 900mm. No flow design required, if the capacity of the watercourse is not affected by the culvert. Permanent - minimum area 600x 900mm. Flow design required.</p> <p><u>Cable crossing:</u> HDD crossing - minimum depth from cable to hard bed of watercourse to be 2m. 20m buffer zone each side of bank. Open cut crossing - minimum 1m depth from cable to hard bed of all watercourses within IDB district. 2m buffer zone each side of bank.</p> <p><u>Design criteria for proposed works:</u> Temporary – 1 in 30 year without 20% climate change acceptable. Permanent - 1 in 100 year + 45% Climate Change.</p> <p><u>Culvert size:</u> Temporary culvert: large as possible to avoid reduction in capacity. Minimum area 600x 900mm. No flow design required if</p>	<p>The FEH catchment descriptors have been used to obtain the greenfield runoff rates in accordance with KCC.</p> <p>Temporary design criteria: 1 in 30-year storm event without 20% climate change allowance acceptable.</p>

Consultee	Date/ Document	Comment	Response / where addressed in the Drainage Strategy report
Drainage Board (IDB). SEAL-MMD-SEAL-ENG-TCN-0404.	January 2023 / Sea Link River Stour IDB Initial Review Meeting	the capacity of the watercourse is not affected by the culvert. Permanent culvert: Minimum area 600x 900mm. Flow design required. <u>Depth of Cable in Crossing:</u> HDD crossing: minimum depth from cable to hard bed of watercourse to be 2m. Open cut crossing: Minimum 1m depth from cable to hard bed of all watercourses within IDB district.	Permanent design criteria: 1 in 100-year storm event plus 45% climate change allowance.
November 2022 / Memorandum of Understanding River Stour IDB. SEAL-MMD-SEAL-ENG-REP-0480	January 2025 / Memorandum of Understanding River Stour IDB SEAL-MMD-SEAL-ENG-REP-0480	<u>Buffer Zone</u> IDB will require consenting within 8m (each side) of an IDB watercourse for any work, including storing of material. HDD Crossing: 20m buffer zone each side of the bank required. Open cut crossings: 2m buffer zone each side of the bank required <u>Maximum Discharge Rates</u> IDB will not accept any additional flows into their watercourses, only greenfield runoff will be accepted into IDB watercourses.	Maximum discharge rates: 2 l/ha/s as minimum discharge rate into IDB watercourses. This will be dependent on size of catchment upstream of the flow control device. This will be refined at later stage of the project using QBAR calculations. Possibly to use 5 l/s discharge if the catchment area is large enough.

Appendix E Drainage Strategy Summary Form

Appendix C. Drainage Strategy Summary



1. Site details	
Site/development name	Sea Link - Kent onshore
Address including post code	Minster Marshes, Minster, Thanet, Kent, England, CT12 4HE, United Kingdom
Grid reference	E 632243 N 163071
LPA reference	N/A
Type of application	Outline <input type="checkbox"/> Full <input checked="" type="checkbox"/> Discharge of Conditions <input type="checkbox"/> Other <input type="checkbox"/>
Site condition	Greenfield <input checked="" type="checkbox"/> Brownfield <input type="checkbox"/>

2. Existing drainage		Document/Plan where information is stated:	
Total site area (ha)			
Impermeable area (ha)	19.88		
Final discharge location	Infiltration <input type="checkbox"/> Watercourse <input checked="" type="checkbox"/> Sewer <input type="checkbox"/> Tidal reach/sea <input type="checkbox"/>		
Greenfield discharge rate (l/s) for existing site area	QBAR (l/s)	36.49	not calculated
	1 in 1 year (l/s)		
	1 in 30 year (l/s)		
	1 in 100 year (l/s)		
3. Proposed drainage areas		Document/Plan where information is stated:	
Impermeable area (ha)	Roof	3.02	
	Highway/road	16.86	
	Other paved areas	0	
	Total	19.88	
Permeable area (ha)	Open space	N/A	
	Other permeable areas	31.17	
	Total	31.17	
Final discharge location	Infiltration <input type="checkbox"/> Infiltration rate _____ m/s Watercourse <input checked="" type="checkbox"/> Sewer <input type="checkbox"/> Tidal reach/sea <input type="checkbox"/>		
Climate change allowance included in design	20% <input type="checkbox"/> 30% <input type="checkbox"/> 40% <input type="checkbox"/> 45% <input checked="" type="checkbox"/>		

4. Post-Development Discharge rates, without mitigation			Document/Plan where information is stated:
Developed discharge rates (l/s)	1 in 1 year		not calculated
	1 in 30 year		
	1 in 100 year		
	1 in 100 year + CC		
5. Post-Development Discharge rates, with mitigation			Document/Plan where information is stated:
Describe development drainage strategy in general terms: Runoff to be collected from roofs and roads. Due to there being negligible infiltration potential, attenuation basins are proposed with controlled discharges to adjacent watercourses.			see Drainage Strategy
(a) No control required, all flows infiltrating <input type="checkbox"/>			
(b) Controlled developed discharge rates (l/s)	1 in 1 year	67.19	Multiple discharge locations, shown on drainage layout plans (see Drainage Strategy)
	1 in 30 year	67.19	
	1 in 100 year	67.19	
	1 in 100 year + CC	67.19	
6. Discharge Volumes			Document/Plan where information is stated:
	Existing volume (m ³)	Proposed volume (m ³)	not calculated
1 in 1 year			
1 in 30 year			
1 in 100 year			
1 in 100 year + CC			

All information presented above should be contained within the attached Flood Risk Assessment, Drainage Strategy or Statement and be substantiated through plans and appropriate calculations.

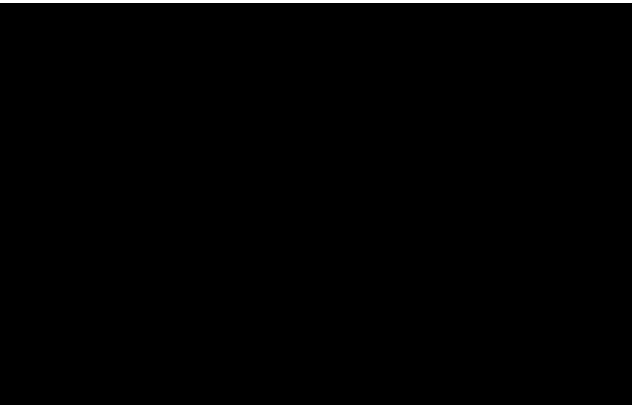
Form completed by	
Qualifications	
Company	
Telephone	
Email	
On behalf of (client's details)	National Grid
Date	15/09/2025

National Grid plc
National Grid House,
Warwick Technology Park,
Gallows Hill, Warwick.
CV34 6DA United Kingdom

Registered in England and Wales
No. 4031152
nationalgrid.com